

# humiSteam x-plus

steam humidifiers

# CAREL



**ENG** User manual

**→ LEGGI E CONSERVA  
QUESTE ISTRUZIONI ←**  
**→ READ AND SAVE  
THESE INSTRUCTIONS ←**

T e c h n o l o g y & E v o l u t i o n



**WARNINGS**



The CAREL S.p.A. humidifiers are advanced products, whose operation is specified in the technical documentation supplied with the product or can be downloaded, even prior to purchase, from the website [www.carel.com](http://www.carel.com). Each CAREL S.p.A. product, in relation to its advanced level of technology, requires setup/configuration/programming/commissioning to be able to operate in the best possible way for the specific application. The failure to complete such operations, which are required/indicated in the user manual, may cause the final product to malfunction; CAREL S.p.A. accepts no liability in such cases.

The customer (manufacturer, developer or installer of the final equipment) accepts all liability and risk relating to the configuration of the product in order to reach the expected results in relation to the specific final installation and/or equipment. CAREL S.p.A. may, based on specific agreements, acts as a consultant for the installation/commissioning/use of the unit, however in no case does it accept liability for the correct operation of the humidifier and the final installation if the warnings or suggestions provided in this manual or in other product technical documents are not heeded. In addition to observing the above warnings and suggestions, the following warnings must be heeded for the correct use of the product:

• **DANGER OF ELECTRIC SHOCK**

The humidifier contains live electrical components. Disconnect the mains power supply before accessing inside parts or during maintenance and installation.

• **DANGER OF WATER LEAKS**

The humidifier automatically and constantly fills/drains certain quantities of water. Malfunctions in the connections or in the humidifier may cause leaks.

• **DANGER OF BURNS**

The humidifier contains high temperature components and delivers steam at 100°C/ 212°F.

**Important:**

- The installation of the product must include an earth/ground connection, using the special yellow-green terminal available in the humidifier.
- The environmental and power supply conditions must conform to the values specified on the product rating labels.
- The product is designed exclusively to humidify rooms either directly or through distribution systems (ducts).
- Only qualified personnel who are aware of the necessary precautions and able to perform the required operations correctly may install, operate or carry out technical service on the product.
- Only water with the characteristics indicated in this manual must be used for steam production.
- All operations on the product must be carried out according to the instructions provided in this manual and on the labels applied to the product. Any uses or modifications that are not authorised by the manufacturer are considered improper. CAREL S.p.A. declines all liability for any such unauthorised use.
- Do not attempt to open the humidifier in ways other than those specified in the manual.
- Observe the standards in force in the place where the humidifier is installed.
- Keep the humidifier out of the reach of children and animals.
- Do not install and use the product near objects that may be damaged when in contact with water (or condensate). CAREL S.p.A. declines all liability for direct or indirect damage following water leaks from the humidifier.
- Do not use corrosive chemicals, solvents or aggressive detergents to clean the inside and outside parts of the humidifier, unless specifically indicated in the user manual.
- Do not drop, hit or shake the humidifier, as the inside parts and the linings may be irreparably damaged.

CAREL S.p.A. adopts a policy of continual development. Consequently, CAREL reserves the right to make changes and improvements to any product described in this document without prior warning. The technical specifications shown in the manual may be changed without prior warning.

The liability of CAREL S.p.A. in relation to its products is specified in the CAREL S.p.A. general contract conditions, available on the website [www.carel.com](http://www.carel.com) and/or by specific agreements with customers; specifically, to the extent where allowed by applicable legislation, in no case will CAREL S.p.A., its employees or subsidiaries be liable for any lost earnings or sales, losses of data and information, costs of

replacement goods or services, damage to things or people, downtime or any direct, indirect, incidental, actual, punitive, exemplary, special or consequential damage of any kind whatsoever, whether contractual, extra-contractual or due to negligence, or any other liabilities deriving from the installation, use or impossibility to use the product, even if CAREL S.p.A. or its subsidiaries are warned of the possibility of such damage.

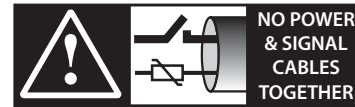

**READ CAREFULLY IN THE TEXT!**

**WARNING:** separate as much as possible the probe and digital input signal cables from the cables carrying inductive loads and power cables to avoid possible electromagnetic disturbance.

Never run power cables (including the electrical panel wiring) and signal cables in the same conduits.

**DISPOSAL**



The humidifier is made up of metal parts and plastic parts. In reference to European Union directive 2002/96/EC issued on 27 January 2003 and the related national legislation, please note that:

1. WEEE cannot be disposed of as municipal waste and such waste must be collected and disposed of separately;
2. the public or private waste collection systems defined by local legislation must be used. In addition, the equipment can be returned to the distributor at the end of its working life when buying new equipment;
3. the equipment may contain hazardous substances: the improper use or incorrect disposal of such may have negative effects on human health and on the environment;
4. the symbol (crossed-out wheeled bin) shown on the product or on the packaging and on the instruction sheet indicates that the equipment has been introduced onto the market after 13 August 2005 and that it must be disposed of separately;
5. in the event of illegal disposal of electrical and electronic waste, the penalties are specified by local waste disposal legislation.

**Warranty on the materials:** 2 years (from the date of production, excluding consumables).



**Approval:** the quality and safety of CAREL S.P.A. products are guaranteed by the ISO 9001 certified design and production system, as well as by the 



mark.



# CONTENT

<b>1. INTRODUCTION AND ASSEMBLY</b>	<b>7</b>	<b>8. INSTALLER MENU</b> 	<b>25</b>
1.1 humiSteam x-plus (UEX*).....	7	8.1 Type of control .....	25
1.2 Dimensions and weights .....	7	8.2 Probe configuration .....	25
1.3 Opening the packaging.....	7	8.3 Operating options .....	25
1.4 Positioning .....	7	8.4 Drain options .....	25
1.5 Wall-mounting.....	7	8.5 Water conductivity .....	25
1.6 Removing the front cover.....	8	8.6 Supervisor.....	26
1.7 Fitting the front cover .....	8		
1.8 Components and accessories.....	9	<b>9. MAINTENANCE MENU</b> 	<b>27</b>
<b>2. WATER CONNECTIONS</b>	<b>10</b>	9.1 Reset configurations.....	27
2.1 Supply water .....	12	9.2 System info.....	27
2.2 Drain water .....	12	9.3 Manual procedure.....	27
2.3 Drain tempering.....	12	9.4 Change cylinder.....	27
<b>3. STEAM DISTRIBUTION</b>	<b>13</b>	9.5 Alarm history.....	27
3.1 CAREL jet distributors (SDPOEM00**) .....	13	<b>10. TABLE OF ALARMS</b>	<b>28</b>
3.2 CAREL linear distributors for air ducts (DP***DRU) .....	13	<b>11. MAINTENANCE AND SPARE PARTS</b>	<b>30</b>
3.3 CAREL steam blowers (VSDU0A*, models UE001 to UE018 only) .....	13	11.1 Spare parts for models UE001 to UE018 .....	30
3.4 Steam hoses.....	14	11.2 Spare parts for models UE025 to UE065.....	33
3.5 Condensate drain hose .....	14	11.3 Spare parts for models UE090 to UE130.....	36
<b>4. ELECTRICAL CONNECTIONS</b>	<b>15</b>	11.4 Cleaning and maintenance of the cylinder.....	38
4.1 Preparing the electric cableways .....	15	11.5 Mechanically draining the water in the cylinder.....	38
4.2 Power cable connection .....	15	11.6 Cylinder connection .....	39
4.3 Control signals ( M2.1 - M2.8; M7.1 - M7.2) .....	15	11.7 Cleaning and maintenance of the other components.....	39
4.4 Alarm contact (M6.1 - M6.3) .....	17	<b>12. WIRING DIAGRAMS</b>	<b>40</b>
4.5 Dehumidification contact (M5.1 - M5.2).....	17	12.1 Diagram of single-phase models UE001 to UE009(208-230V).....	40
<b>5. REMOTE TERMINAL, GSM MODEM AND SUPERVISORY NETWORK</b>	<b>18</b>	12.2 Diagram of three-phase models UE003 to UE018 (208-230-460-575V) .....	41
5.1 Remote display terminal.....	18	12.3 Diagram of three-phase models UE025(208-230-460-575V), UE35(208-230-460-575V) and UE045(460-575V) .....	42
5.2 GSM network connection (send SMS).....	18	12.4 Diagram of three-phase models UE045 (208-230 V) and UE065 (460-575 V).....	43
5.3 Supervisory network (J19) .....	18	12.5 Diagram of three-phase models UE090 to UE130.....	44
Modbus® protocol.....	19	<b>13. GENERAL FEATURES AND MODELS</b>	<b>45</b>
5.4 Cascading control of other units.....	20	13.1 humiSteam models and electrical specifications .....	45
<b>6. STARTING AND USER INTERFACE</b>	<b>21</b>	13.2 Technical specifications.....	47
6.1 Starting.....	21	13.3 Models of steam hoses.....	47
6.2 Stopping.....	21	13.4 Models of concentrated jet steam distributors.....	48
6.3 First start-up (setting the language).....	21	13.5 Models of linear distributors.....	48
6.4 Keypad .....	21	13.6 CONTROLLING THE BOARD VIA NETWORK .....	50
6.5 "Main" screen.....	21	<b>14. TECHNICAL APPENDIX</b>	<b>54</b>
6.6 "INFO" screens (read-only).....	21	14.1 Operating principle .....	54
6.7 "SET" screen .....	22	14.2 Control principles.....	54
6.8 Main menu.....	23	14.3 Operation with two cylinders (only UE090...UE130).....	55
<b>7. USER MENU</b> 	<b>24</b>	14.4 Supply water conductivity .....	55
7.1 Alarm thresholds .....	24	14.5 Automatic draining .....	55
7.2 System clock.....	24	14.6 Automatic insufficient supply water management .....	56
7.3 Enable scheduler.....	24	14.7 Cylinder "exhaustion" and cylinder " pre-exhaustion" alarms .....	56
7.4 Setting the time bands.....	24		
7.5 Weekly scheduler.....	24		
7.6 Scheduled set points.....	24		

**UE xxx x x x U 0**  

①
②
③
④
⑤
⑥
⑦

1	ID prefix;																															
2	rated instant steam production in kg/h / lbr/h:	<table style="border-collapse: collapse; width: 100%;"> <thead> <tr> <th style="text-align: left; width: 15%;"><b>mod.</b></th> <th style="text-align: left;"><b>production</b></th> </tr> </thead> <tbody> <tr><td>001</td><td>1.5/3.3</td></tr> <tr><td>003</td><td>3/6.6</td></tr> <tr><td>005</td><td>5/11</td></tr> <tr><td>008</td><td>8/17.6</td></tr> <tr><td>009</td><td>9/19.8</td></tr> <tr><td>010</td><td>10/22</td></tr> <tr><td>015</td><td>15/33</td></tr> <tr><td>018</td><td>18/39.7</td></tr> <tr><td>025</td><td>25/55.1</td></tr> <tr><td>035</td><td>35/77.2</td></tr> <tr><td>045</td><td>45/99.2</td></tr> <tr><td>065</td><td>65/143.3</td></tr> <tr><td>090</td><td>90/198.4</td></tr> <tr><td>130</td><td>130/286.6</td></tr> </tbody> </table>	<b>mod.</b>	<b>production</b>	001	1.5/3.3	003	3/6.6	005	5/11	008	8/17.6	009	9/19.8	010	10/22	015	15/33	018	18/39.7	025	25/55.1	035	35/77.2	045	45/99.2	065	65/143.3	090	90/198.4	130	130/286.6
<b>mod.</b>	<b>production</b>																															
001	1.5/3.3																															
003	3/6.6																															
005	5/11																															
008	8/17.6																															
009	9/19.8																															
010	10/22																															
015	15/33																															
018	18/39.7																															
025	25/55.1																															
035	35/77.2																															
045	45/99.2																															
065	65/143.3																															
090	90/198.4																															
130	130/286.6																															
3	type of control:	X= X-plus controller																														
4	type - power supply:	<table style="border-collapse: collapse; width: 100%;"> <thead> <tr> <th style="text-align: left; width: 15%;"><b>type</b></th> <th style="text-align: left;"><b>V</b></th> </tr> </thead> <tbody> <tr><td>U= 208</td><td>1~N</td></tr> <tr><td>D= 230</td><td>1~N</td></tr> <tr><td>W= 208</td><td>3~</td></tr> <tr><td>K= 230</td><td>3~</td></tr> <tr><td>L= 400</td><td>3~</td></tr> <tr><td>M= 460</td><td>3~</td></tr> <tr><td>N= 575</td><td>3~</td></tr> </tbody> </table>	<b>type</b>	<b>V</b>	U= 208	1~N	D= 230	1~N	W= 208	3~	K= 230	3~	L= 400	3~	M= 460	3~	N= 575	3~														
<b>type</b>	<b>V</b>																															
U= 208	1~N																															
D= 230	1~N																															
W= 208	3~																															
K= 230	3~																															
L= 400	3~																															
M= 460	3~																															
N= 575	3~																															
5	option:	0= standard cylinder C= standard openable cylinder 1= cylinder for low conductivity 2= openable cylinder for low conductivity																														
6-7		0U= UL certified version for the American market																														

**Table 1.a**

# 1. INTRODUCTION AND ASSEMBLY

## 1.1 humiSteam x-plus (UEX\*)

Range of isothermal immersed electrode humidifiers with liquid crystal display for the control and distribution of steam.

Models available (identifiable from the code shown on the product):

- UE001, UE003, UE005, UE008, UE009, UE010, UE015, UE018: steam production capacity up to 18 kg/h (39.7 lb/h), water connections under the base of the humidifier;
- UE025, UE035, UE045, UE065: steam production capacity from 25 to 65 kg/h (55.1 to 144.3 lb/h), water connections on the side of the humidifier;
- UE090, UE130: steam production capacity from 90 to 130 kg/h (198.4 to 286.6 lb/h), water connections on the side of the humidifier.

## 1.2 Dimensions and weights

All dimensions are given in millimeters and the inch dimensions are in parenthesis.

Models UE001 to UE018

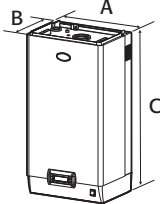

Fig. 1.a

		UE001 to UE008	UE009 to UE018
dimensions mm (in)	A	365 (14.4)	365 (14.4)
	B	275 (10.8)	275 (10.8)
	C	620 (24.4)	712 (28.0)
weights kg (lb)	packaged	16 (35.3)	20 (44.0)
	empty	13.5 (29.8)	17 (37.5)
	installed*	19 (41.9)	27 (59.5)

Models UE025 to UE065

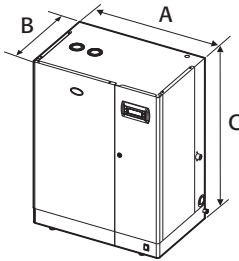

Fig. 1.b

		UE001 to UE008	UE009 to UE018	UE025 to UE045	UE045** to UE065
dimensions mm (in)	A	365 (14.4)	365 (14.4)	545 (21.5)	635 (25.0)
	B	275 (10.8)	275 (10.8)	375 (14.8)	465 (18.3)
	C	620 (24.4)	712 (28.0)	815 (32.0)	890 (35.0)
weights kg (lb)	packaged	16 (35.3)	20 (44.0)	39 (86.0)	51 (112.4)
	empty	13.5 (29.8)	17 (37.5)	34 (74.9)	44 (97.0)
	installed*	19 (41.9)	27 (59.5)	60.5 (133.4)	94 (207.2)

Models UE090 to UE130

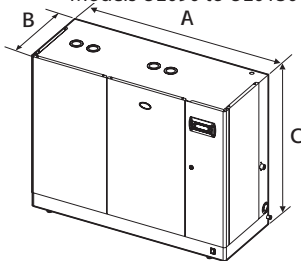

Fig. 1.c

		UE090	UE130
dimensions mm (in)	A	1150 (45.3)	1150 (45.3)
	B	465 (18.3)	465 (18.3)
	C	890 (35.0)	890 (35.0)
weights kg (lb)	packaged	77 (169.8)	81 (178.6)
	empty	70 (154.3)	74 (163.1)
	installed*	130 (286.6)	170 (374.8)

\*: in operating conditions

\*\* : 230 Vac model

## 1.3 Opening the packaging



- make sure the humidifier is intact upon delivery and immediately notify the transporter, in writing, of any damage that may be due to careless or improper transport;
- move the humidifier to the site of installation before removing from the packaging, grasping the neck only from underneath the base;
- open the cardboard box, remove the protective material and remove the humidifier, keeping it vertical at all times.

## 1.4 Positioning

- the unit is designed to be mounted on a wall that is strong enough to support the weight in normal operating conditions (see Wall-mounting below). Models UE025 to UE130 can stand on the floor;
- to ensure correct steam distribution, position the humidifier near the point of steam distribution;
- make sure the humidifier is level, allowing the minimum clearances (see Fig. 1.d) for maintenance operations.



**Important:** during operation the metal casing heats up and the rear part resting against the wall may reach temperatures in excess of 60 °C (140 °F).

### Distances from walls

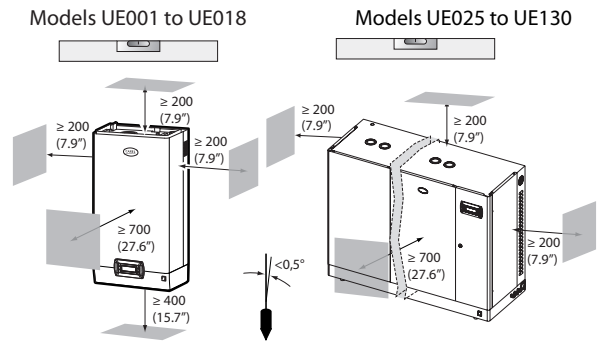

Fig. 1.d

## 1.5 Wall-mounting

Fit the humidifier on the wall using the support bracket and the screw kit supplied (for the dimensions see Fig. 1.d).

Assembly instructions:

1. unscrew the wall bracket from the humidifier bracket;
2. fasten the wall bracket (see Fig. 1.e), checking horizontal position with a level; if installed on a masonry wall, the plastic anchor plugs (dia. 8 mm/0.31") and screws (dia. 5 mm x L= 50 mm/ 0.19" x L= 1.97") supplied can be used;
3. hang the appliance to the bracket using the slot on the top edge of the rear of the appliance;
4. secure the appliance to the wall through the hole in the center on the rear of the unit. For the weights and dimensions see Figs. 1.a, 1.b, 1.c.



The supplied wall anchors and screws should only be used on concrete walls.

Spacing of the holes on the wall  
Models UE001 to UE065

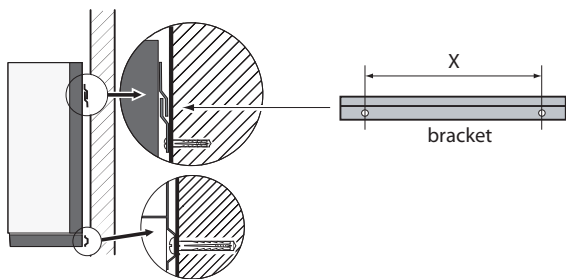
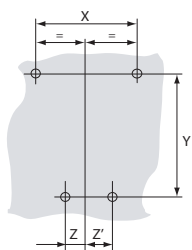

Fig. 1.e

Spacing of the holes on the wall  
Models UE001 to UE018



distance mm (in)	Models	
	UE001 to UE008	UE009 to UE018
X	270 (10.7)	270 (10.7)
Y	496 (19.5)	591 (23.3)
Z	107 (4.2)	107 (4.2)
Z'	163 (6.4)	163 (6.4)

Fig. 1.f

Models UE025 to UE065

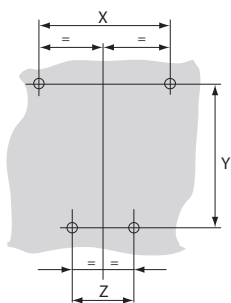

distance mm (in)	UE025 to UE045	UE045* to UE065
	X	310 (12.2)
Y	655 (25.8)	730 (28.7)
Z	127.5 (5.0)	122.5 (4.8)
Z'	172.5 (6.8)	167.5 (6.6)

\* 230 Vac models only

Fig. 1.g

Models UE090 to UE130

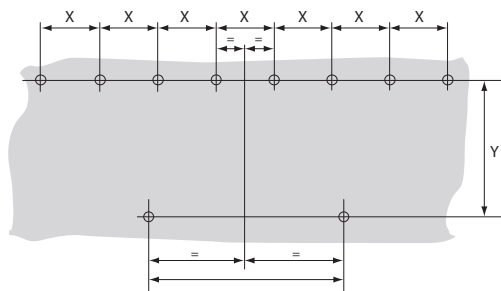

Fig. 1.h

distance mm (in)	Models UE090 to UE130
X	150 (5.9)
Y	740 (29.1)
Z	850 (33.5)

## 1.6 Removing the front cover

Models UE001 to UE018

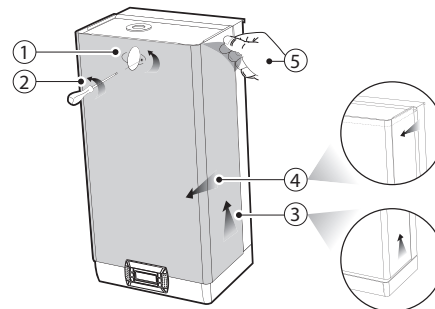

Fig. 1.i

1. turn oval-shaped label with the Carel logo, revealing the head of the grounding screw below;
2. remove the screw using a screwdriver;
3. hold the cover by the sides and lift it around 20 mm (0.79"), releasing it from the protruding edges of the humidifier;
4. remove the cover by moving it forwards;
5. remove the protective film

Models UE025 to UE130

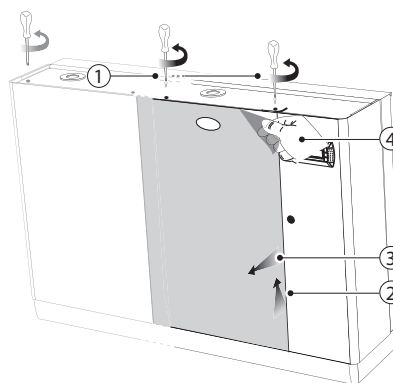

Fig. 1.j

1. remove the screws from the top of the humidifier using a screwdriver;
2. hold the cover/covers from the top and lift it around 20 mm (0.79");
3. remove the cover/covers by moving it/them forwards;
4. remove the protective film (on all the outside surfaces of the humidifier).

## 1.7 Fitting the front cover

Models UE001 to UE018

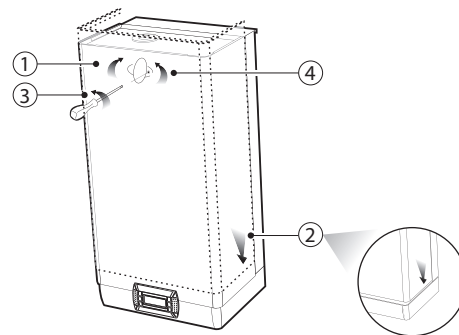

Fig. 1.k

1. turn the red oval-shaped plate with the CAREL logo, revealing the fastening hole below;
2. slip the cover onto the frame (keeping it slightly raised and tilted), until it rests on the rear edges;
3. tighten the earth screw using a screwdriver;

- turn the red oval-shaped plate with the CAREL logo until covering the fastening holes.

Models UE025 to UE130

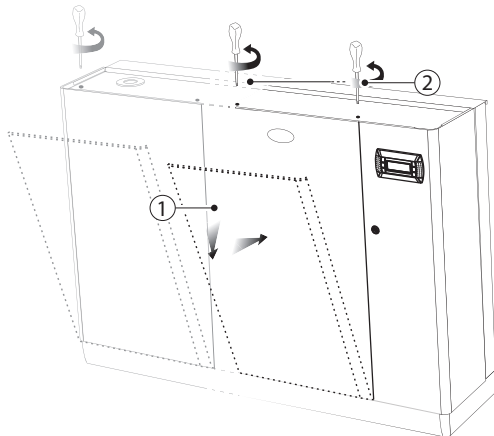

Fig. 1.l

- slip the cover/covers onto the frame (keeping it/them slightly raised and tilted), until it rests on the rear edges;
- tighten the screws on the top of the humidifier using a screwdriver.

**Important:** in models UE025 to UE130 open the electrical compartment on the humidifier using the lock with slot.

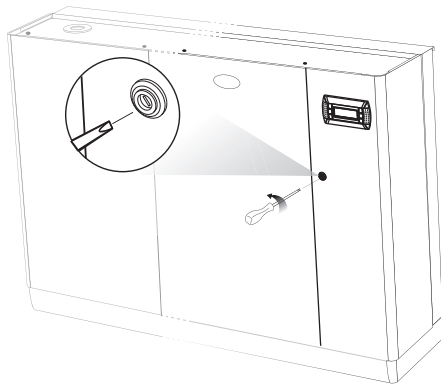

Fig. 1.m

## 1.8 Components and accessories

Once having opened the packaging and removed the front cover of the humidifier, make sure the following are included:



- kit of screws with plugs for wall-mounting;

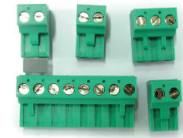

- kit code UEKTERM000 of connectors for the electronic board



- models UE025 to UE130 only: angular plastic hose (drain water connection).



- models UE001 to UE018 use fill hose connection FWH3415000, and models UE025 to UE130 use code FWHDCV00000 non-return valve with connection pipe for fill water and use code FWH3415000 for inlet drain temperening.



- UEKFILT000 for the gasket / fill valve kit that is supplied with models UE001 to UE018.

## 2. WATER CONNECTIONS

**Important:** before proceeding, disconnect the power supply.

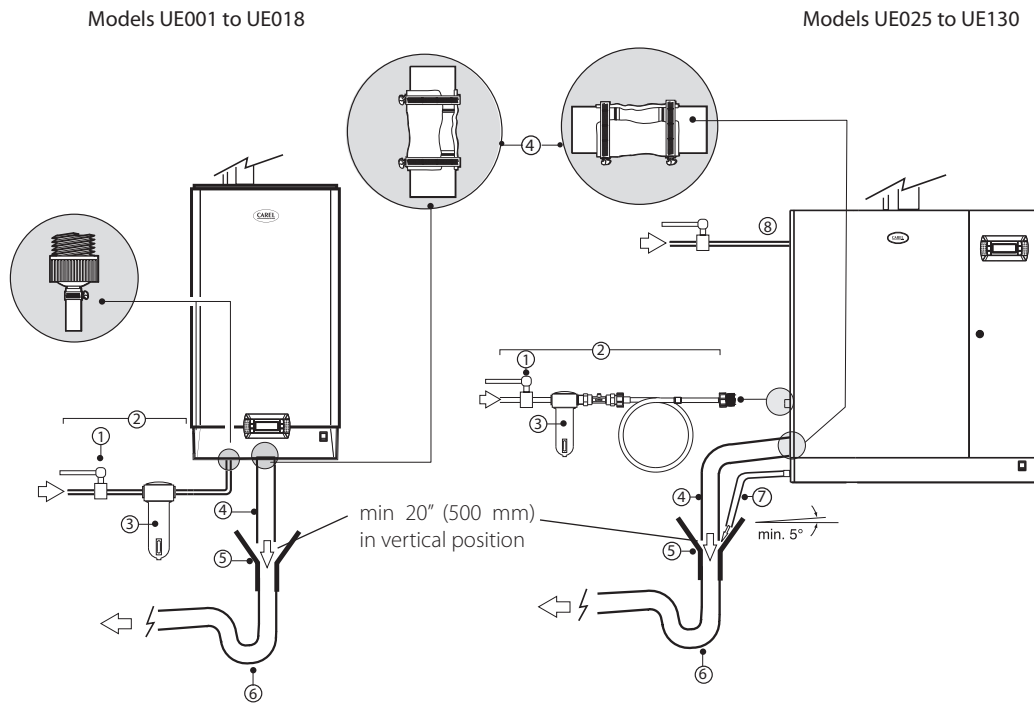

Fig. 2.a

### Water connections:



- 1. install a manual valve upstream of the installation (to be able to shut off the water supply);
- 2. connect the humidifier to the water supply. On models UE001 to UE018, use a hose with 3/4" G fittings (see par. "Technical specifications" page 41, compatible CAREL hose: code FWH3415000). On models UE025 to UE130 connect the hose with the non-return valve supplied (code FWHDCV0000) to prevent the water inside the humidifier from coming into contact with the mains water;
- 3. install a mechanical filter to trap any solid impurities (to be connected downstream of the manual valve);
- 4. connect a section of non-conductive pipe or hose for draining (resistant to temperatures of 100 °C (212 °F) and with a minimum inside diameter of 40 mm/1.6" up to UE018, and 50 mm/1.9" for models UE025 to UE130);
- 5. prepare a funnel to interrupt continuity in the drain line funnel for required air gap, can be composed of a piping reducer;
- 6. connect a drain trap to prevent the return of bad odors (minimum inside diameter of 40 mm/1.6" up to UE018, and 50 mm/1.9" for models UE025 to UE130);
- 7. in models UE025 to UE130: connect a drain hose from the bottom tank of the humidifier (this can run into the drain funnel/air gap reducer coupling).
- 8. in models UE025 to UE130: connect the hose FWH3415000 for the drain tempering valve.

**Important:** when installation is completed, flush the supply hose for around 30 minutes by piping water directly into the drain, without sending it into the humidifier. This will eliminate any scale or processing residues that may block the drain pump and cause foam when boiling.

Fittings provided for the water connections:

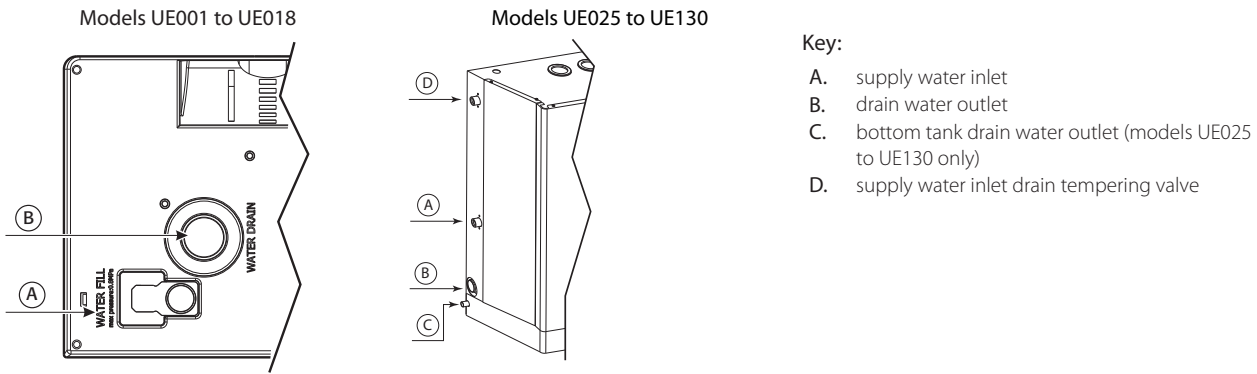

Fig. 2.b

Key:

- A. supply water inlet
- B. drain water outlet
- C. bottom tank drain water outlet (models UE025 to UE130 only)
- D. supply water inlet drain tempering valve

**Hydraulic interfaces dimensions**

Interfaces dimensions drain/fill

dimensions mm (in)	UE001 to UE018
D	72.6 (2.86)
D'	125.4 (4.94)
E	52.6 (2.07)
E'	107.5 (4.23)

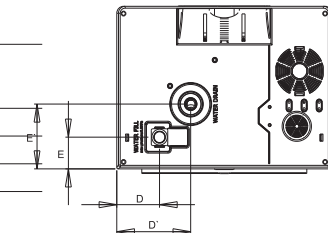

Interfaces dimensions steam outlet and condensed drain

dimensions mm (in)	UE001 to UE018
F	126.7 (5)
F'	224 (8.82)
G	137.9 (5.43)
G'	21.7 (0.85)

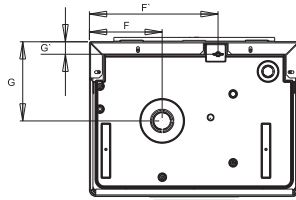

Interfaces dimensions drain/fill

dimensions mm (in)	UE025 to UE045	UE045* to UE065	UE090 to UE130
I		40 (1.58)	
I'		72 (2.83)	60 (2.36)
I''		10.2 (0.4)	
I'''			78 (3.1)
L		123.2 (4.85)	
L'		231.2 (9.10)	
L''		49.1 (1.93)	
L'''	678 (26.7)	752 (29.6)	672 (26.5)
L''''			833 (32.7)

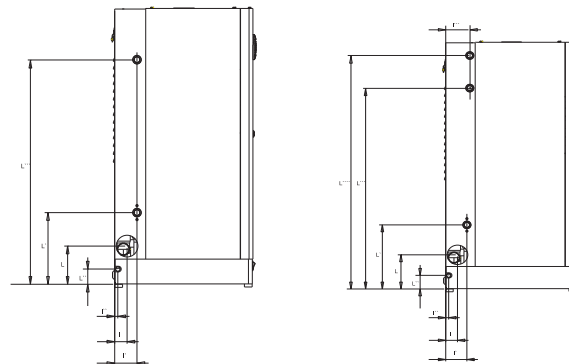

Interfaces dimensions steam outlet and condensed drain

dimen. mm (in)	UE025 to UE045	UE045* to UE065	UE090 to UE130
M	172 (6.77)	223.7 (8.81)	
M'	30.2 (1.19)	30.2 (1.19)	
N	181 (7.13)	181 (7.13)	
N'		100 (3.94)	
N''	55 (2.17)	61 (2.40)	
N'''			641 (2.53)
N''''			100 (3.94)

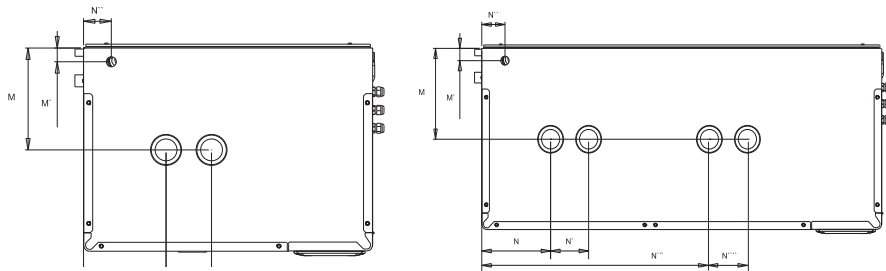

\* 230 Vac models only

## 2.1 Supply water

Only use mains water with:

- pressure between 0.1 and 0.8 MPa (14.5 and 116 PSI), temperature between 1 and 40 °C (33.8 and 104 °F) and an instant flow-rate no lower than the rated flow of the fill solenoid valve, the connection is G3/4M (see par. "Technical specifications" page 47);
- range hardness 10° to 40 °f (equal to 400 ppm of CaCO<sub>3</sub>), conductivity: 75 to 1250 µS/cm;
- no organic compounds.

supply water characteristics	unit of measure	normal water		water with low salt content	
		min.	max.	min.	max.
Hydrogen ions (pH)		7	8,5	7	8,5
Specific conductivity at 20°C (σ <sub>R,20°C</sub> )	µS/cm	300	1250	75	350
Total dissolved solids (c <sub>R</sub> )	mg/l	( <sup>1)</sup> )	( <sup>1)</sup> )	( <sup>1)</sup> )	( <sup>1)</sup> )
Dry residue at 180°C (R <sub>180</sub> )	mg/l	( <sup>1)</sup> )	( <sup>1)</sup> )	( <sup>1)</sup> )	( <sup>1)</sup> )
Total hardness (TH)	mg/l CaCO <sub>3</sub>	100 ( <sup>2)</sup> )	400	50 ( <sup>2)</sup> )	150
Temporary hardness	mg/l CaCO <sub>3</sub>	60 ( <sup>3)</sup> )	300	30 ( <sup>3)</sup> )	100
Iron + Manganese	mg/l Fe+Mn	=	0,2	=	0,2
Chlorides	ppm Cl	=	30	=	20
Silica	mg/l SiO <sub>2</sub>	=	20	=	20
Residual chlorine	mg/l Cl <sup>-</sup>	=	0,2	=	0,2
Calcium sulphate	mg/l CaSO <sub>4</sub>	=	100	=	60
Metallic impurities	mg/l	0	0	0	0
Solvents, thinners, detergents, lubricants	mg/l	0	0	0	0

Tab. 3.a

(<sup>1)</sup>)= values depend on the specific conductivity; in general:

$$C_R \cong 0,65 * \sigma_{R,20^\circ C}; R_{180} \cong 0,93 * \sigma_{R,20^\circ C}$$

(<sup>2)</sup>)= not less than 200% of the chloride content in mg/l CL

(<sup>3)</sup>)= not less than 300% of the chloride content in mg/l CL

There is not reliable relationship between hardness and conductivity of the water.

### Important:

- do not treat the water with softeners, this may cause foam, affecting the operation of the unit;
- do not add disinfectants or anticorrosive compounds to the water, as these are potential irritants;
- the use of well water, industrial water or water from cooling circuits and, in general, any potentially chemically or bacteriologically contaminated water is not recommended.

## 2.2 Drain water

- this contains the same substances dissolved in the supply water, however in larger quantities;
- it may reach a temperature of 100 °C (212 °F);
- it is not toxic and can be drained into the sewerage system.

## 2.3 Drain tempering

The unit is fitted with a tempering valve that, opening at the same time as the drain valve, adds cold water to the drain line, thus ensuring a maximum temperature of the drain water of 60°C/140°F.

### 3. STEAM DISTRIBUTION

#### 3.1 CAREL jet distributors (SDPOEM00\*\*)

These can be fitted horizontally or vertically (hole facing upwards).  
See page 48 for the models of distributors.

Assembly instructions (see Fig.3.a):

- make a series of holes on the wall according to the distributor drilling template;
- insert the distributor;
- fasten the flange using 4 screws.

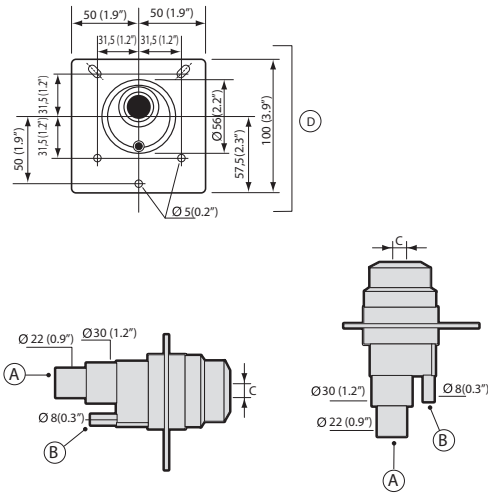

Fig. 3.a

Key:

- A. steam inlet
  - B. condensate drain
  - C. steam outlet.
- the dimensions of the hole vary depending on the models of distributor:  
model SDPOEM0000: hole made manually, up to 30 mm (1.2") in diameter);  
model SDPOEM0012: diameter of the hole 12 mm (0.5");  
model SDPOEM0022: diameter of the hole 22 mm (0.9").
- D drilling template

**Note:** if steam hoses with an inside diameter of 30 mm (1.2") are used, remove the 22 mm (0.9") steam inlet section.

#### 3.2 CAREL linear distributors for air ducts (DP\*\*\*DRU)

Install away from obstacles (curves, branches, changes in cross-section, grills, filters, fans).

Minimum distance between the distributor and the obstacle: 1/1.5 m (3.3/4.9 ft). Increase the distance if:

- the air speed increases in the duct,
- the relative humidity of the air increases before and after humidification,
- the turbulence decreases.

See page 49 for installation examples.

Assembly instructions (see Fig.3.b):

- make a series of holes on the wall according to the distributor drilling template (included in the packaging with the distributor);
- fasten the flange using 4 screws.

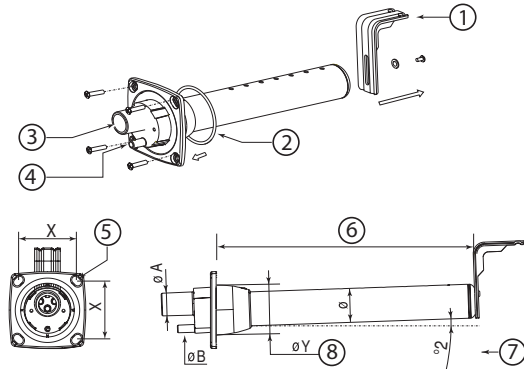

Fig. 3.b

Key:

- 1 "L"-shaped mounting support (where featured)
- 2 flange gasket
- 3 steam inlet (ØA)
- 4 condensate drain (ØB)
- 5 screw diameter (see the instruction sheet supplied with the distributor)
- 6 length (depending on the model of distributor, see par. "10.5" page 42)
- 7 angle (around 2°) for draining the condensate.
- 8 diameter of the hole on the wall (ØY)

Dimensions in mm (in)

	CAREL linear distributors		
	DP***D22RU	DP***D30RU	DP***D40RU
ØA	22 (0.9")	30 (1.18")	40 (1.57")
ØB	10 (0.4")	10 (0.4")	10 (0.4")
ØY	58 (2.3")	68 (2.7")	89 (3.5")
Ø	35 (1.4")	45 (1.8")	60 (2.4")
X	68 (2.7")	77 (3.0")	99 (3.9")

Tab. 3.a

**! Important:**

- 1. fit the distributor at a slight incline (at least 2°, to prevent the return of condensate);
- 2. the "L"-shaped mounting support (see part 1 Fig. 3.c) is supplied with steam distributor models from DP085\* to DP025\*. For shorter lengths, the support can be supplied as an option (code 18C478A088).

#### 3.3 CAREL steam blowers (VSDU0A\*, models UE001 to UE018 only)

Steam distributors for humidifiers with flow rates up to 18 kg/h (39.7 lb/h). Can be connected on top of the humidifier, or separately in another location (see the figure below).

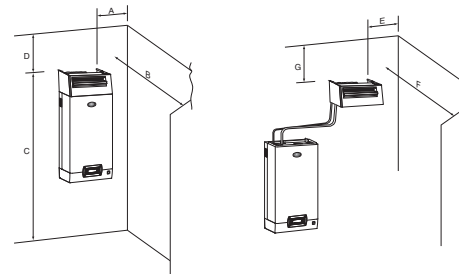

DIMENSIONS (m)/(feet)	A	B	C	D	DIMENSIONS (m)/(feet)	E	F	G
		>0,5 (1.64)	>5 (16.4)	≥2,1 (6.9)		>1 (3.3)		>0,5 (1.64)

Fig. 3.c

**! Important:** For correct distribution of the steam, observe the distance shown in the figure above.

### 3.4 Steam hoses

- use CAREL hoses (max. 4 m ( max. 13 feet)) long, see “Models of steam hoses”, page 47). Rigid pipes may break and cause steam leaks;
- avoid the formation of pockets or traps (causes of condensate);
- avoid restricting the hose due to tight bends or twisting.
- fasten the end of the hose to the connectors on the humidifier and the steam distributor using metal clamps, so that these do not detach due to the high temperature.
- Avoid situations that cause stress on the outlet of the steam cylinder and on the distributor pipe (see minimum diameter of curving).

### 3.5 Condensate drain hose

During the operation of the humidifier some of the steam may condense, causing a decline in efficiency and noise (gurgling). To drain the condensate, connect a drain hose with a drain trap and a minimum slope of 5° to the bottom of the humidifier (see Fig. 3.d). CAREL condensate drain hoses: code CHOSE00038

**! Important:** the drain trap in the condensate drain hose must be filled with water before starting the humidifier.

Example of correct and incorrect installation of the steam hose and condensate drain hose.

### Final checks

- the steam outlet hoses run upwards and the distributor has a minimum incline of 2° upwards (see Fig. 3.c);
- the ends of the hose are tightened to the fittings with metal clamps;
- the curves in the tubing are sufficiently wide (radius > 300 mm / 11.8”) so as to not cause bending or choking;
- the steam hose has no pockets or traps for condensate to form;
- the paths of the steam and condensate hoses are as described in this chapter (see Fig. 3.d);
- the length of the steam hose is no greater than 4 metres (13.1 feet);
- the incline of the steam hose is sufficient to allow correct draining of the condensate (> 20° for the upward sections, > 5° for the downward sections);
- the incline of the condensate hose is at least 5° at every point;
- the condensate hose always follows a downwards path and features a drain trap (filled with water before starting operation) to avoid steam being released.

installer

user

service

YES

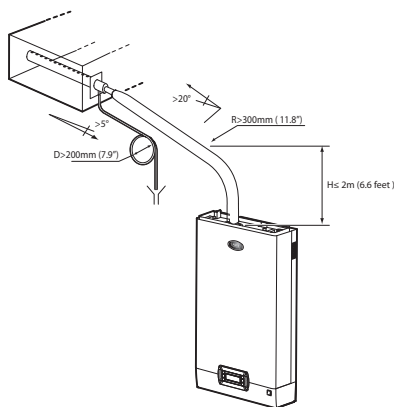

YES

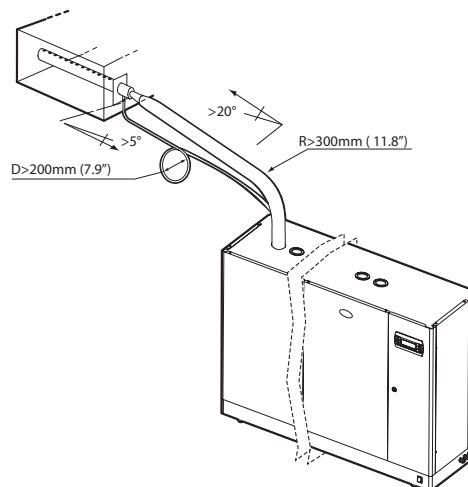

All UE models

YES

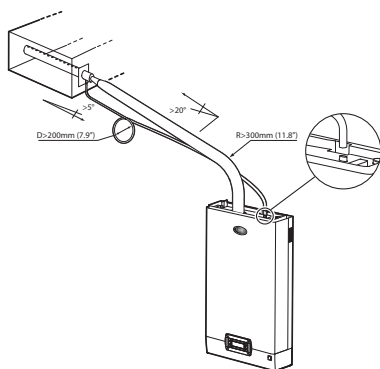

Models UE001 to UE025  
(1): connection with fill tank

Models UE25 to UE130

(1) extend the hose inside the humidifier to the bottom tank.

NO

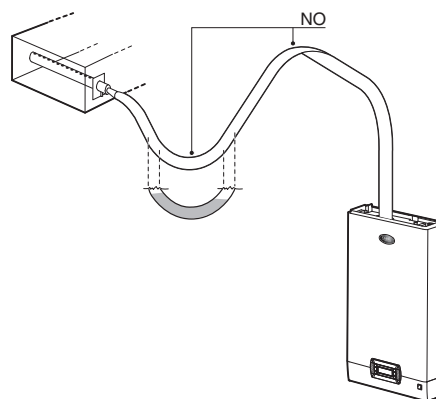

All UE models

Fig. 3.d

## 4. ELECTRICAL CONNECTIONS

### 4.1 Preparing the electric cableways

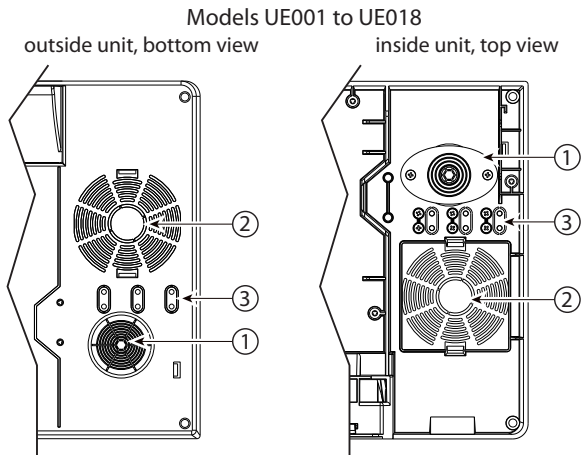

Fig. 4.a

Models UE025 to UE130  
outside unit, side view

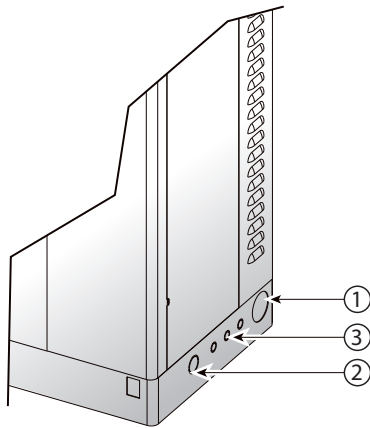

Fig. 4.b

Key to Figs. 4.a & 4.b:

1. power cable inlet;
2. optional utility cable inlet (after drilling).
3. probe cable inlet. On models UE001 to UE018, remove the plastic "tab" and use it to secure the cable (held in place by the screws provided).

### 4.2 Power cable connection

Before making the connections, ensure that the machine is disconnected from the mains power supply.

Check that the power supply voltage of the appliance corresponds to the value indicated on the rating plate inside the electrical panel. Insert the power and ground connection cables into the electrical panel compartment using the tear-proof cable gland supplied, or through the cable gland with cable stop, and connect the ends to the terminals (see Fig. 4.c). The humidifier power line must be fitted, by the installer, with a disconnecting switch and fuses protecting against short circuits. Table 13.a lists the recommended cross-sections of the power supply cable and the recommended fuse ratings; note, however, that this data is purely a guide and, in the event of non-compliance with local standards, the latter must prevail.

**Note:** to avoid unwanted interference, the power cables should be kept apart from the probe signal cables.

Single-phase models

Three-phase models

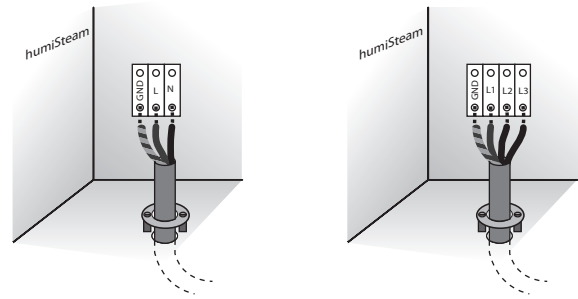

Fig. 4.c (view inside unit, electrical compartment)

**Important:** connect the yellow-green cable to the earth point (GND).

### 4.3 Control signals ( M2.1 - M2.8; M7.1 - M7.2)

Steam production by the humidifier is enabled or controlled.

For connection of control signals, use the connection kit (supplied in the packaging) and run the cables from the humidifier through the cable gland (Fig. 4.a or 4.b).

Depending on the type of signal used, steam production can be enabled and/or managed in different ways.

1. Enable steam production using:

**REMOTE CONTACT (ON/OFF action)**

- jumper outputs M7.1 and M7.2
- connect outputs M2.7 and M2.8 to a remote contact (e.g.: switch, timer,...)

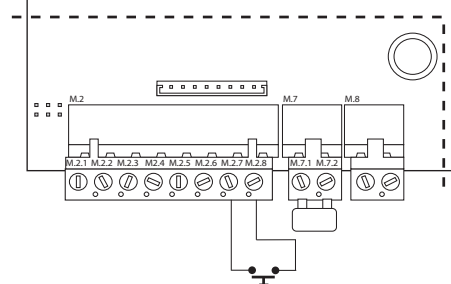

Fig. 4.d

**HUMIDISTAT (ON/OFF action)**

- connect outputs M7.1 and M7.2 to a humidistat
- jumper outputs M2.7 and M2.8

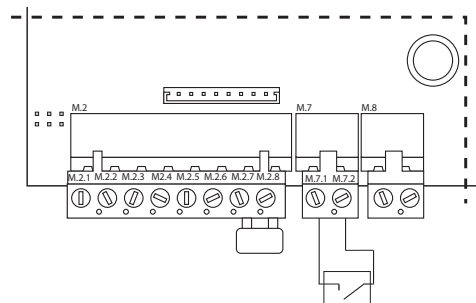

Fig. 4.e

**HUMIDISTAT and REMOTE CONTACT (ON/OFF action)**

- connect outputs M7.1 and M7.2 to a humidistat
- connect outputs M2.7 and M2.8 to a remote contact (e.g.: switch, timer,...)

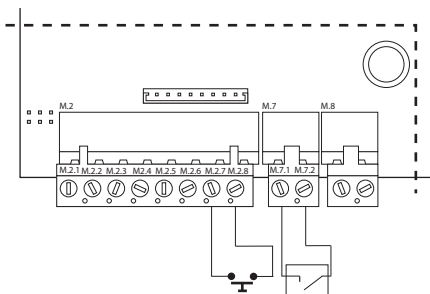

Fig. 4.f

**2. Enable and control the steam production using:**

**PROPORTIONAL EXTERNAL CONTROLLER**

jumper outputs M2.7 and M2.8 or connect to a remote contact

- connect outputs M2.1 and M2.2 to an external controller
- The humidifier can be programmed to receive one of the following signals:

Voltage: 0 to 1 Vdc, 0 to 10 Vdc, 2 to 10V

Current : 0 to 20 mA, 4 to 20 mA

Potentiometric: 135-1000 ohm, 0-135 ohm

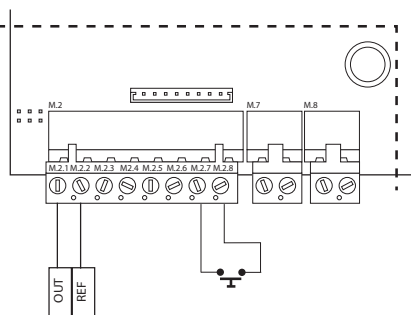

Fig. 4.g

**PROPORTIONAL EXTERNAL CONTROLLER WITH CAREL LIMIT PROBE**

- jumper outputs M2.7 and M2.8 or connect to a remote contact
- connect the limit probe to terminals M2.3, M2.5 and M2.6
- The humidifier can be programmed to receive one of the following signals:

Voltage: 0 to 1 Vdc, 0 to 10 Vdc, 2 to 10V

Current : 0 to 20 mA, 4 to 20 mA

Potentiometric: 135-1000 ohm, 0-135 ohm

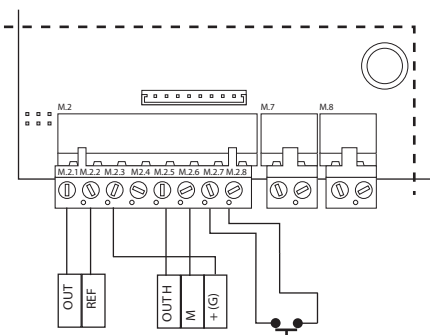

Fig. 4.h

The reference (zero) of the external controller must be connected to the GND terminal (M2.2) and the control signal to terminal M2.1.

**CONTROL WITH CAREL MAIN PROBE**

Complete action with control according to the humidity measured.

- jumper outputs M2.7 and M2.8 or connect to a remote contact
- connect the main probe to terminals M1.2, M2.2 and M2.3

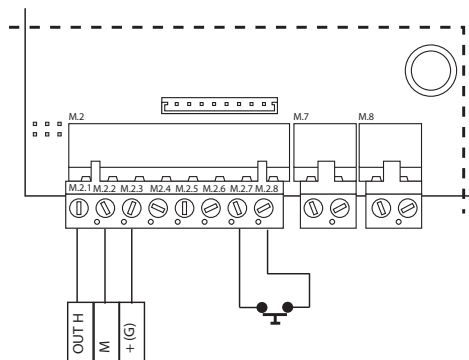

Fig. 4.i

**CONTROL WITH CAREL MAIN PROBE AND LIMIT PROBE**

- jumper outputs M2.7 and M2.8 or connect to a remote contact
- connect the main probe to terminals M1.2, M2.2 and M2.3
- connect the limit probe to terminals M2.3, M2.5 and M2.6

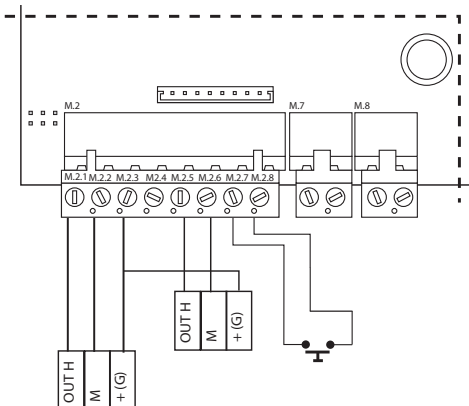

Fig. 4.j

**CONTROL WITH CAREL TEMPERATURE PROBE**

The humidifier can be connected to both active probes (voltage or current signal), and to passive NTC temperature probes (variable resistance).

**CAREL active probe connection:**

jumper outputs M2.7 and M2.8 or connect to a remote contact  
connect the temperature probe to terminals M1.2, M2.2 and M2.3

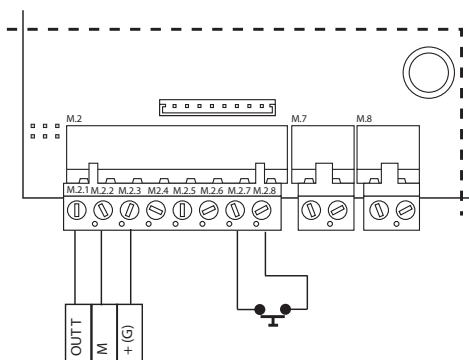

Fig. 4.k

CAREL NTC probe connection:

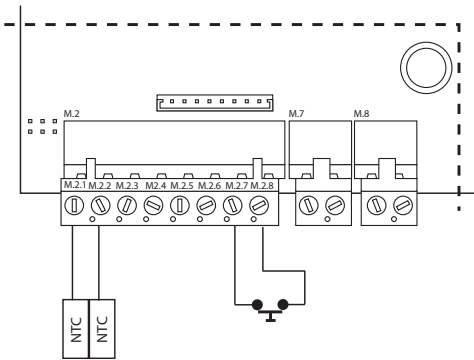

Fig. 4.l

**CAREL PROBES AVAILABLE:**

- room: code DPWC112000
- air ducts: code DPDC112000 and code DPDC212000
- industrial: DPPC112000 and DPPC212000

**If non-CAREL probes are used, check:**

- voltage signal: 0 to 1 Vdc, 0 to 10 Vdc, 2 to 10 Vdc, terminal M2.1 (GND: M2.2);
  - current signal: 4 to 20, 0 to 20 mA, terminal M2.4 (GND: M2.6).
- In addition, depending on the type of power supply:
- +15 V, terminal M2.3;
  - +1 Vdc 135 ohm, terminal M2.4.

**INPUT PROBE CONFIGURATION (pin strip connectors JS5, JS6)**

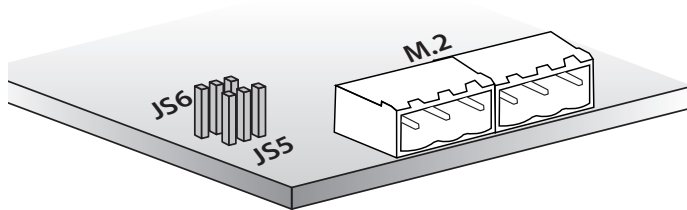

Fig. 4.m (detail of electronic board, in the humidifier electrical compartment)

pin strip	configuration	position	
		0 to 10Vdc 2 to 10Vdc	0 to 1 Vdc, 4 to 20/0 to 20 mA, NTC probes
JS5	main probe		
JS6	limit probe		

**Important:**

- to avoid unbalanced control, the ground of the probes or the external control devices must be connected to the ground of the appliance's controller.
- If ON/OFF terminals are not closed, all the internal and external devices managed by the controller will be disabled, with the exception of the drain pump for emptying the unit after extended periods.

**Note:** in industrial environments (IEC EN61000-6-2), the cables leaving the unit must not exceed 30 m (98 feet) in length, except for the main probe (terminals M2 pin 1-2-3-4-5-6), the remote ON/OFF digital input (terminal M2 pin 7-8) and cable shields for RS485 communication.

**4.4 Alarm contact (M6.1 - M6.3)**

Contact available for the remote signalling of one or more alarms.

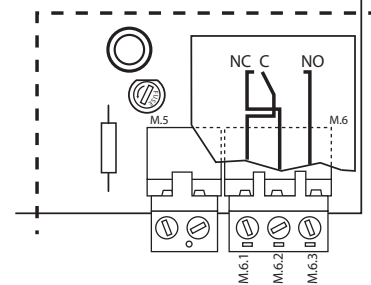

Fig. 4.n

Electrical specifications: 250 Vac; I<sub>max</sub>: 2 A resistive 2 A inductive.

**Note:** use clamps on the relay terminal blocks (alarm, utilities) to prevent the cables from being detached.

**4.5 Dehumidification contact (M5.1 - M5.2)**

When the humidifier is used in the control modes with main probe or main probe plus limit probe, a contact (NO - normally open - voltage free) can be used to activate an external dehumidification device.

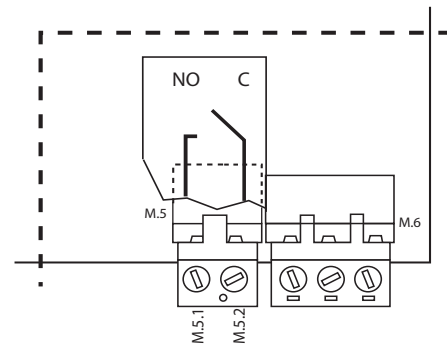

Fig. 4.o

**Final checks**

The following conditions represent correct electrical connection:

- the rated voltage of the appliance corresponds to the rated supply voltage;
- the external fuses / breakers installed are suitable for the line and the power supply voltage;
- a mains disconnect switch has been installed to disconnect power to the humidifier when required;
- the humidifier has been correctly grounded;
- the power cable is fastened using the tear-proof cable gland;
- terminals M2.7 and M2.8 are jumpered or connected to an enable-operation contact;
- if the humidifier is controlled by an external control device, the earth of the signal is electrically connected to the controller earth.

## 5. REMOTE TERMINAL, GSM MODEM AND SUPERVISORY NETWORK

### 5.1 Remote display terminal

The display terminal can be detached from the humidifier and moved to another place.

Depending on the distance required, the following are necessary:

- up to 50 metres ( 164 feet ): 6-wire telephone cable and two EMC filters (code 0907858AXX) (see Fig. 5.a);
- up to 200 metres: two CAREL TCONN6J000 boards, 6-wire telephone cables and an AWG20-22 shielded cable with 3 twisted pairs (for the connection of the two boards, Fig. 5.b).

**Note:** to fill the empty space left by the display terminal on the humidifier, use CAREL kit code HCTREW0000.

Remote connection of the terminal up to max 50 m ( 164 feet )

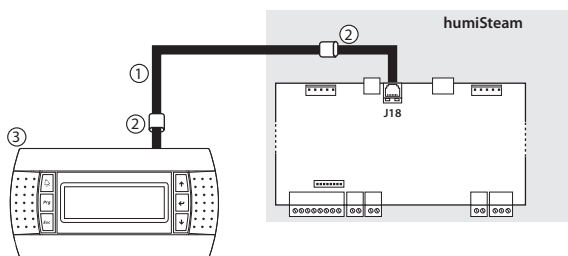

Fig. 5.a

Key:

- 1 telephone cable (up to 50 m ( 164 feet ) distance);
- 2 EMC filters (code 0907858AXX) to be applied to the ends of the telephone cable;
- 3 remote display terminal.

Remote connection of the terminal up to 200 m ( 656.1 feet )

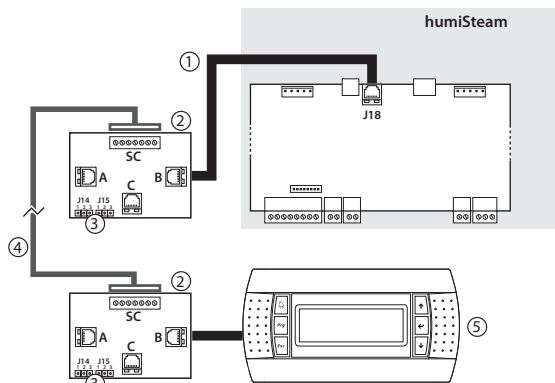

Fig. 5.b

Key:

- 1 telephone cable (up to 0.8 m ( 2.6 feet ) distance);
- 2 CAREL TCONN6J000 board;
- 3 pin strip J14 and J15 in position 1-2 (power supply available on the telephone connectors A, B and C and screw SC);
- 4 WG20-22 shielded cable with 3 twisted pairs to move the display terminal up to 200 m away. Connection to the TCONN6J00 board:

terminal SC	function
0	EARTH (shield)
1	+VRL
2	GND
3	RX/TX-
4	RX/TX+
5	GND
6	+VRL

- 5 remote display terminal

### 5.2 GSM network connection (send SMS)

The humidifier can be configured to send SMS message for alarms and malfunctions (see menu installer > supervisor > GSM protocol).

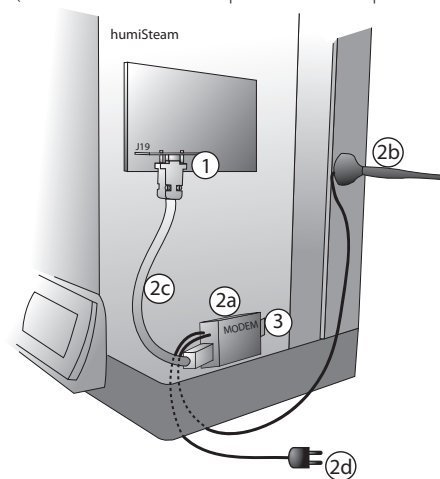

Fig. 5.c (inside humidifier, electrical compartment)

Key:

- 1 electronic board PCOI00MDM0 (to be connected to connector J19 on the humidifier board)
- CAREL GSM kit PLW0P65M00, made up of:
  - 2.a modem
  - 2.b antenna (with magnetic base)
  - 2.c serial cable
  - 2.d power supply
- 3 SIM card to be inserted in the modem. Make sure that the access password (PIN number) is not enabled

### 5.3 Supervisory network (J19)

The humidifier is equipped serial interface of the following:

- PCOS004850 (for connections protocol Carel, Modbus®, Winload).

Instead of the supplied, they can be connected to the following optional boards:

- PCO10000F0 for Lon connections;
- PCO100MDM0 for RS232 connections;

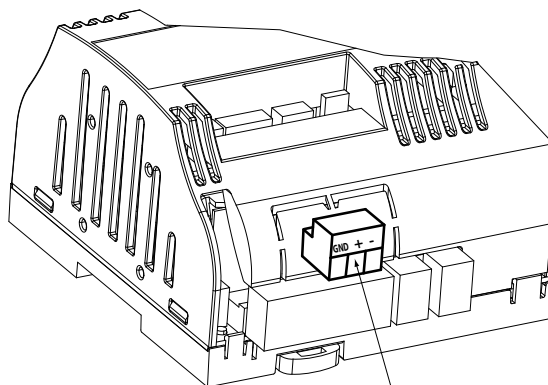

connection terminal block for RS-485 board

Fig. 5.d (detail of the electronic board, humidifier electrical compartment)

For the connecting remove the cover , and connect cards optional connector J19

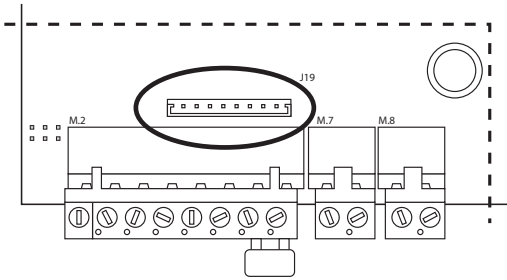

**Modbus® protocol**

The protocol Modbus ® is available by selecting from the menu installer mask supervisor.

Chapter 13.6 shows a list of variables and the corresponding addresses. For multiple read/writes, the maximum number of “Register” or “Coil” variables is 20.

The following functions are available:

- MB\_READ\_COIL\_STATUS 1: used to request the status (ON or OFF) of a certain number of “Coil” variables (binary, 1 bit), starting from the specified address.
- MB\_READ\_INPUT\_STATUS 2: operationally identical to the above.
- MB\_READ\_HOLDING\_REG 3: used to request the value of a consecutive block of “Register” variables (numeric, 16 bit).
- MB\_READ\_INPUT\_REG 4: operationally identical to the above.
- FORCE\_SINGLE\_COIL 5: used to set the status of an individual “Coil” variable (binary, 1 bit) to ON or OFF (specifying the address of the bit in question).
- MB\_PRESET\_SINGLE\_REG 6: used to set the value of an individual “Register” variable (numeric, 16 bit).
- MB\_FORCE\_MULTIPLE\_COIL 15: used to set the status of a consecutive block of “Coil” variables (binary, 1 bit) (specifying the number of bits and number of bytes).
- MB\_PRESET\_MULTIPLE\_REG 16: used to set the value of a consecutive block of “Register” variables (numeric, 16 bit).

Exceptions managed:  
 01 illegal function  
 02 illegal data address

**⚠ Important:** for the tLAN and pLAN connections in residential household (IEC EN 55014-1) and residential (IEC EN 61000-6-3) environments, use shielded cable (with shield connected to GND). This warning also applies to the cables leaving the unit.

### 5.4 Cascading control of other units

The steam production reached can exceed the maximum capacity of the master unit by connecting one or more slaves

- Master: UEX unit with analogue output to control the other units
- Slave: UEX/UEY unit that operates based on the analogue control signal received from the master
- each UEX master unit can control up to 30 UEX slave units or 14 UEY slave units.

Parameter P0 on each single unit (master or slave) only affects the production on that unit.

If the master is disabled by remote contact or serial connection, production will stop on the slaves.

Some alarms also stop the slaves (see the table of alarms) GRAPH

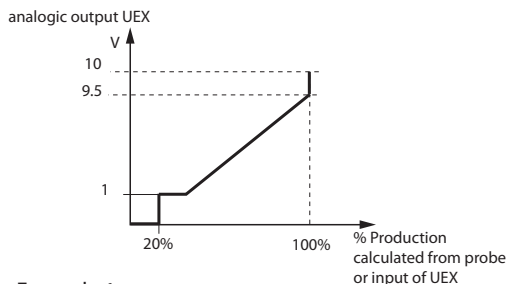

Example 1

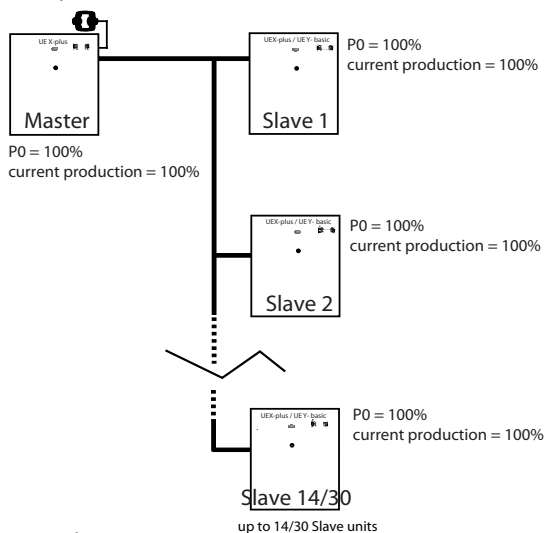

Example 2

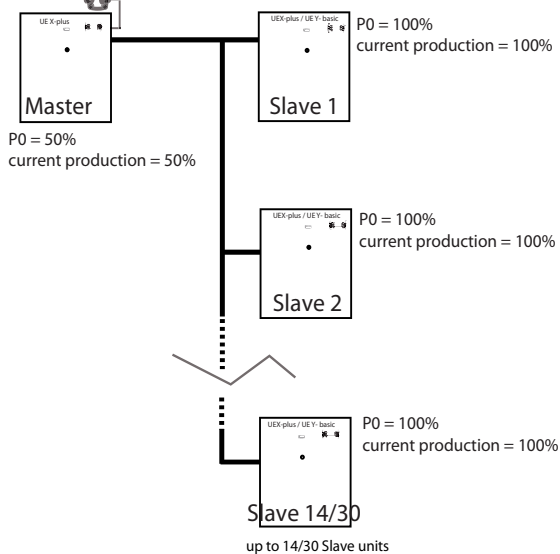

Example 3

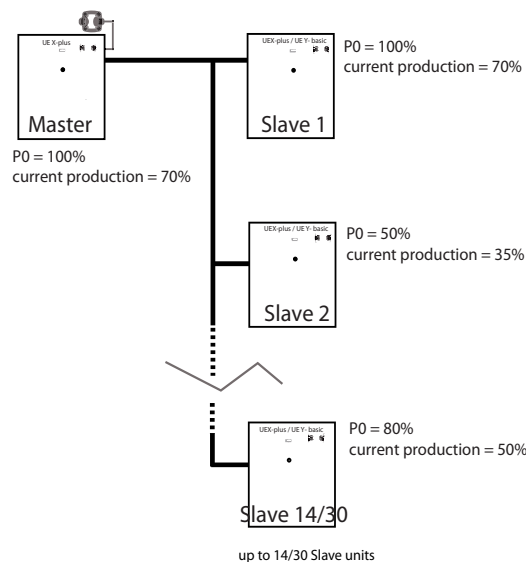

Connection between UEX Master and UEX/UEY Slave.  
Use shielded cable for the connection.

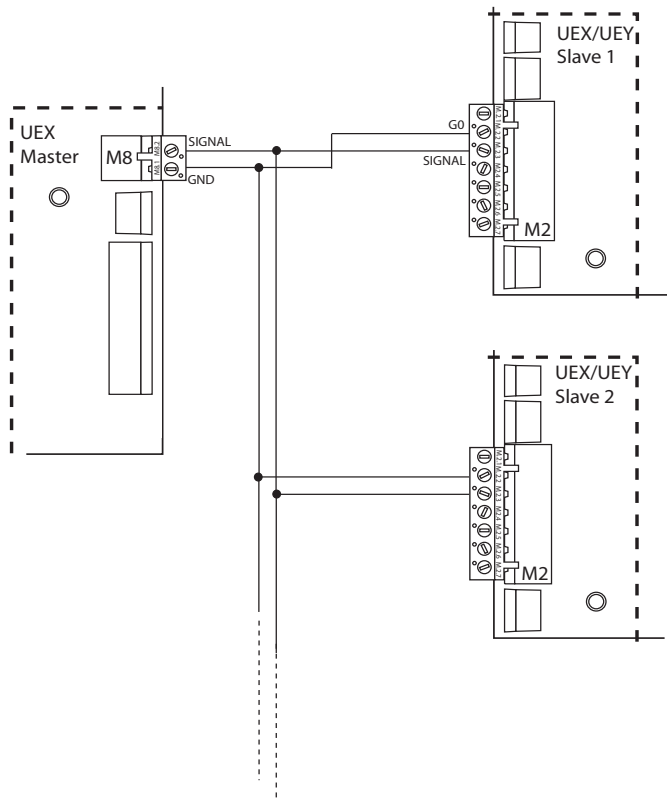

## 6. STARTING AND USER INTERFACE

Before starting the humidifier, check:

- 
- water connections: Fig. 2.a page 10. In the event of water leaks do not start the humidifier before having resolved the problem;
- steam distribution: Fig. 3.d page 13;
- electrical connections chap. 4

### 6.1 Starting

- 1 ON
- 2 if the cylinder is new, run a pre-wash cycle (the cylinder is filled and emptied three times, cleaning the inside walls from impurities, see menu maintenance >change cylinder > flush new cylinder).

### 6.2 Stopping

- 1 empty the water in the cylinder to avoid stagnation: see manual drain on "SET" screens).



### 6.3 First start-up (setting the language)

Select language:

1. English
2. Italiano
3. Deutsch
4. Francais
5. Espaniol

Press UP to select the number corresponding to the desired language and then ENTER to confirm. This screen remains displayed for 60 seconds.

Subsequently, the following screen will be displayed:

Show language mask to unit start-up...  
Yes/no

- YES: the screen for choosing choose the language will be displayed when the humidifier is started the next time;
- NO: the screen for choosing choose the language will no longer be displayed on power-up.

**Note** The language can also be changed from the maintenecce menu.

### 6.4 Keypad

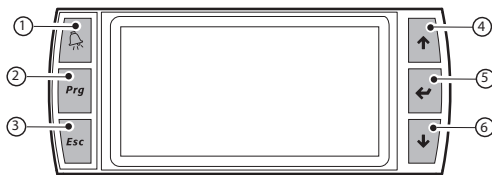

Fig. 6.a

button	function
(1) alarm	list active alarms and reset any alarms
(2) PRG	return to the "main" screen from the "Main" screen access the main menu
(3) ESC	return to the previous screen/display
(4) UP	circular navigation inside the menus, the screens, the parameters and the values of the parameters from the "main" screen access an "INFO" screens

(5) ENTER	select and confirm (like the "Enter" key on a computer keyboard) from the "SET" main menu
(6) DOWN	circular navigation inside the menus, the screens, the parameters and the values of the parameters from the "main" screen access an "INFO" screens

### 6.5 "Main" screen

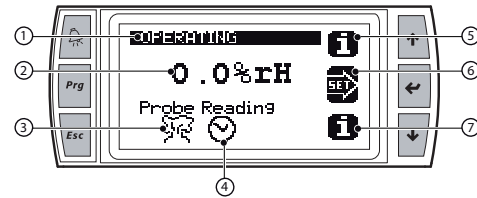

Fig. 6.c

symbol	function
(1)	description of the activity in progress(*)
(2)	value read according to the type of signal connected
(3)	status of steam production(**): in progress (as per the figure)
	alarm
	disabled
	no request
(4)	time bands set
(5)	access to the "INFO" screen (UP or DOWN button)
(6)	access to the "SET" screen (ENTER button)

(\*) Type of descriptions:

- **OPERATING:** steam production in progress,
- **BLOCKING ALARM:** steam production disabled by alarm,
- **OFF BY SUPERVISOR:** steam production disabled by supervisor,
- **OFF BY SCHEDULER:** steam production disabled during a pre-set scheduler,
- **OFF BY REMOTE:** steam production interrupted through the opening of the "Remote ON/OFF" contact.
- **OFF BY KEYBOARD:** steam production disabled by keyboard (see "SET" mask), page 22
- **NO REQUEST:** humidifier on, without steam production request.

(\*\*) In the models with two cylinders, the symbols for the operating status of both cylinders are displayed.

### 6.6 "INFO" screens (read-only)

Series of read-only screens for displaying the main humidifier status values. To access, press UP or DOWN from the "Main" screen. There are 3 "INFO" screens (4 if the humidifier has two cylinders); to move from one screen to the next, press UP or DOWN.

Press ESC to return to the "Main" screen.

"INFO" screens:

Info	display	UOM
<b>Status</b>	(*)	
<b>Steam production</b>	value	lbs/h
<b>Current</b>	value	A
<b>Dehumidifier</b>	ON/OFF	
<b>Alarm relay</b>	ON/OFF	
<b>Conductivity</b>	value	uS/cm

(\*) humidifier status:

- **Operating:** steam production in progress;
- **Alarms:** signalling of one or more alarms;

- **OFF by Superv.:** steam production disabled by supervisor;
- **OFF by Sched.:** steam production disabled during a pre-set sheduler;
- **Remote Off:** isteam production interrupted through the opening of the "Remote ON/OFF" contact;
- **OFF by Keyb.:** steam production disabled by keyboard (see "SET" mask);
- **Manual Proc.:** humidifier functions managed manually (maintenance menu > manual procedure);
- **No request:** humidifier on, without steam production request.

Hour counter	display	UOM
Total hours	value	h

Cylinder 1

Operating hours	value	h
-----------------	-------	---

Cylinder 2

Operating hours	value	h
-----------------	-------	---

Time bands active	YES/NO	
-------------------	--------	--

Current		
---------	--	--

Info cylinder 1	display	UOM
-----------------	---------	-----

Cyl. prod.	value	lbs/h
------------	-------	-------

Status	(*)	
--------	-----	--

Activity	cylinder activity (**)	
----------	------------------------	--

Current	value	A
---------	-------	---

Power contactor	YES/NO	
-----------------	--------	--

Fill valve	YES/NO	
------------	--------	--

Drain pump	YES/NO	
------------	--------	--

Info cylinder 2	display	UOM
-----------------	---------	-----

Cyl. prod.	value	lbs/h
------------	-------	-------

Status	(*)	
--------	-----	--

Activity	activity of the cylinder (**)	
----------	-------------------------------	--

Current	value	A
---------	-------	---

Power contactor	YES/NO	
-----------------	--------	--

Fill valve	YES/NO	
------------	--------	--

Drain pump	YES/NO	
------------	--------	--

(\*) cylinder status:

- **Off:** stop steam production (no request or signaling of an alarm)
- **Softstart:** starting steam production;
- **Operating:** steady operation steam production;
- **Low Prod.:** low production;
- **Washing:** cylinder washing in progress.

(\*\*) Activity of the cylinder:

- **Cyl.Off:** stop steam production (no request or signaling of an alarm);
- **Fill:** fill valve operating;
- **Evaporation:** steam production operating;
- **Drain:** drain pump operating;
- **Stop by Al.:** steam production stopped by an alarm;
- **Inact. Drain:** total drain for inactivity;
- **Pre-clean:** new cylinder washing in progress;
- **M. Emptying:** manual drain;
- **Chk .F. Water:** fill water check (from lack of water cylinder alarm);
- **Period FI:** Periodical drain for dilution.

## 6.7 "SET" mask

Used to set the main values for the humidifier.

To access, press ENTER from the "Main" screen, to move from one value to the next press UP (next) or DOWN (previous) and ENTER to confirm.

Press ESC repeatedly to return to the "Main" screen.

Parameter	range	default	UOM
Set point	0 to 100	50	%rH
Humidifier	AUTO / OFF	AUTO	
Max. prod.	20 to 100	100	%
Prop. band.	2 to 19.9	5	%rH
Lim. probe set *	0 to 100	80	%rH
Prop. band *	2 to 19.9	5	%rH

\* visible only if the limit probe is enabled

### Manual drain:

- access the "SET" screen,
  - press UP and DOWN together for 5 seconds
- The same procedure can be repeated to stop the drain cycle

## 6.8 Main menu

To access press PRG from the main screen

Buttons:

- UP and DOWN: navigation inside the sub-menus, screens, and range of values and settings;
- ENTER: confirm and save the changes made;
- ESC: to go back (pressed repeatedly returns to the "Main" screen).

1.	User	1. Alarm thresholds	Main probe threshold Alarm high Alarm high Limit probe threshold Alarm high Alarm delay
		2. System Clock	System Clock Time Day Month Year Format Week Day
		3. Enable Scheduler	Enable Enable Scheduler Enable Scheduler On/Off Variable Setpoint
		4. Define time zone	Define time zone P1-1 P1-2 P2 P3 P4
		5. Weekly scheduler	Weekly scheduler Sunday Monday Tuesday Wednesday Thursday Friday Saturday
		6. Scheduled setp.	Scheduled setpoints Z1 Z2 Z3 Z4

2.	Installer	1. Regulation type	Regulation type Select regulation Probe or signal type main(reg.) Limit Meas. units. Cyl. Sequence
		2. Probes config.	Main probes config. Min value Max value Offset Limit probe config. Min value Max value Offset
		3. Operating options	Option (1/2) Select data view on main mask Cylinder lifetime warning Lifetime limit Alarm relay logic Pulsed alarm relay  Options (2/2) Delay before power-off at set point Dehum. control Dehum. offset Dehum. hyster. Disable complete emptying for foam
		4. Drainage options	Drainage options (1/2) Drain if steam request drops (quick reg.) Power-off electrodes when draining Drain after inactivity time Inactivity days  Drainage options (2/2) Dilution drain time (standard=100) Dilution drain freq.(standard=100) Additional periodic cylinder flush Time interval
		5. Water conductivity	Water conductivity Override conductivity reading (0=no) Conductivity limit Warning Alarm
		6. Supervisor	Supervisor connect. Identification number for BMS Network Com.speed Protocol type Enable On/Off from supervisor

3.	Maintenance	1. Config.restore.	Configuration Save configuration Load configuration Normal Values Restore default parameters humidifier type
		2. System information	System information Bios (only reading) Boot (only reading) Ver. (only reading) Language Show language mask to unit start-up
		3. Manual procedure	Manual proced. Cyl.1 Manual procedure Power contactor Fill valve Drain pump Alarm Dehumidif. Manual proced. Cyl.2 (only 2 cyl. versions) Manual procedure Power contactor Fill valve Drain pump
		4. Change cylinder	Change cylinder 1 Empty cylinder Reset cylinder lifetime counter Last replace (only reading) Flush new cylinder Change cylinder 2 (only 2 cyl. versions) Empty cylinder Reset cylinder lifetime counter Last replace (only reading) Flush new cylinder
		5. Alarm history	Alarm history Alarm (only reading) Time (only reading) Date (only reading)

# 7. USER MENU



installer

user

service

From the main screen press:

- PRG to access the main menu,
- ENTER to select and access the menu user.

User menu screens:

1. Alarm thresholds
2. System clock
3. Enable scheduler
4. Define time zones
5. Weekly scheduler
6. Scheduled setpoint

## 7.1 Alarm thresholds

parameter	par name.	range	default	UOM
Main probe alarm thresholds	High alarm	0 to 100.0	100.0	%
	Low alarm	0 to 100.0	0.0	%
Limit probe alarm thresholds	High alarm	0 to 100.0	100.0	%
	Alarm delay	0 to 999	0	min

## 7.2 System clock

Used to set the timed activation of the humidifier

parameter	range
hour / min	0 to 23 / 0 to 59
day	1 to 31
month	1 to 12
year	00 to 99
format	dd/mm/yy - mm/dd/yy
week day	Sunday to Saturday

## 7.3 Enable scheduler

Enable control of the time bands and the set points

parameter	enable
scheduler On/Off	YES / NO
variable set point	YES / NO

When the time bands are set, the display shows the symbol

## 7.4 Setting the time bands

**Note:** this screen is visible if "scheduler ON/OFF" has been enabled (see the enable scheduler screen).

Set the intervals for the operation of the humidifier over a 24h period (one day):

time band	ON	OFF
P1	P1-1	09:00 - 13:00
	P1-2	14:00 - 21:00
P2	14:00 - 21:00	
P3	always ON	
P4	always OFF	

Parameters P1 to P4 can be used set how many times steam production is enabled/disabled over a 24h period:

### P1 Two daily ON time bands

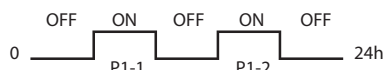

### P2 Individual ON time band

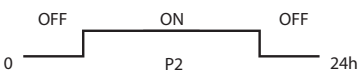

P3 Always ON

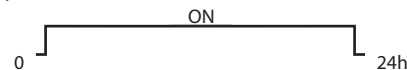

P4 Always OFF

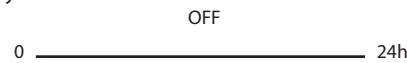

Fig. 7.1

## 7.5 Weekly scheduler

**Note:** this screen is visible if "scheduler ON/OFF" has been enabled (see the enable scheduler screen).

Set the weekly operation of the humidifier, using parameters P1 to P4 (configured in the previous screen)

parameter	type of time band
Monday	P1,...,P4
Tuesday	P1,...,P4
Wednesday	P1,...,P4
Thursday	P1,...,P4
Friday	P1,...,P4
Saturday	P1,...,P4
Sunday	P1,...,P4

## 7.6 Scheduled set points

**Note:** this screen is visible if "variable set point" has been enabled (see the enable scheduler screen).

Set different levels of set points throughout the day (24h):

parameter	ON	SETP.
	hours	%rH
Z1	00:00	0.0...
Z2	00:00	0.0...
Z3	00:00	0.0...
Z4	00:00	0.0...

Parameters Z1 to Z4 can be used to configure up to four different temperature set points at different times of a day (parameters Z1, Z2, Z3, Z4).

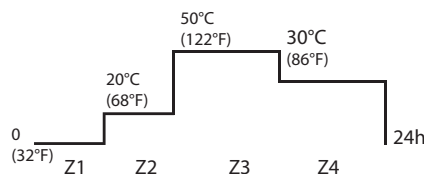

Fig. 7.b

By setting the "daily" and "variable set point" time bands, steam production can be programmed according to the needs of the utility.

Note:

- during the "OFF" time band, the humidifier is NOT actually off, but rather steam production is temporarily disabled, even when setting manually;
- the "daily" time bands have priority over the "variable set point" bands. For example, setting P4 each Monday (humidifier off), parameters Z1, Z2, Z3, Z4 (different set point values) will not be observed, as the humidifier is not programmed to operate on that day.

## 8. INSTALLER MENU

From the main screen press:

- PRG to access the main menu,
- DOWN to select the installer menu,
- ENTER,
- ENTER,
- UP or DOWN to enter the password "77",
- ENTER to confirm and access the installer menu.

Installer menu screens:

1. Regulation type
2. Probe configuration
3. Operating options
4. Drain options
5. Water conductivity
6. Supervisor

To navigate inside the screens:

- UP or DOWN to change the value (within the options/range),
- ENTER to confirm and move the cursor to the next value
- ESC to return to the installer menu.

### 8.1 Type of control

Setting: type of control, type of signal, unit of measure, and in the models with two cylinders, choice between "parallel sequence" or "series sequence".

parameter	options/range	description
Regulation type	%rH probe	humidity control with main probe
	%rH + limit probe	humidity control with main probe and limit probe
	Temperature control	temperature control
	ON/OFF	humidity control with humidistat
	Proportional	proportional control with signal set from external controller
	Proportional + limit	proportional control with signal from external controller and limit probe
Signal type (not visible with ON/OFF control)	0/10 V (default)	
	0/20 mA	
	4/20 mA	
	0-135 ohm	
	135-1000 ohm	
	NTC	
Meas. unit	0/1 V	
	2/10V	
	°C-kg/h	
	°F - lb/hr (default)	
Cyl. sequence for units with two cylinders	parallel (default)	
	series	

### 8.2 Probe configuration

Set the minimum value, maximum value and offset for the probes used.

parameter	parameter	range	default	UOM
Main probe config. (not accessible in ON/OFF control mode)	Min.scale	0 to (Max. scale)	0.0	%rH °C/°F
	Max.scale	(Min.scale) to 250	100.0	%rH °C/°F
	Offset	-10.0 to 10.0	0.0	°C/°F
Limit probe config. (available only in "%rH + limit probe" control mode)	Min.scale	0 to (Max. scale)	0.0	%rH °C/°F
	Max.scale	(Min. scale)...250	100.0	%rH °C/°F
	Offset	-10.0 to 10.0	0.0	°C/°F

### 8.3 Operating options

#### Operating options (1/2)

parameter	range	default	UOM
Select data view on main mask	% rH	% rH	
important: the options for this parameter depend on the type of control selected.	°C-°F		
	Ampere		
	Kg-lb/h		
	hours		
	uS/cm		
	% signal		
cylinder lifetime warning	YES/NO	YES	
cylinder lifetime limit	0 to 4000	1000	hours
alarm relay logic	NO/NC	NO	
pulsed alarm relay	YES/NO	NO	

#### Operating options (2/2)

parameter	range	default	UM	description
Delay before power OFF at set point	0* to 120	0	s	used to delay the stop in production when there is no steam request
Dehumidif. control	YES/NO	NO		
Dehumidif. offset	2.0,...,100.0	10.0	%rH	
Dehumidif. hysteresis	2.0,...,19.9	5.0	%rH	
Disable complete emptying for foam	YES/NO	NO		

\*: 0= deactivated

### 8.4 Drain options

#### Drainage options (1/2)

parameter	range	default	UOM	description
Drain if steam request drops (quick reg.)	YES/NO	YES		the humidifier empties a small amount of water if there is a decrease in steam request
Power-off electrodes when draining	YES/NO	YES		
Drain after inactivity YES/NO	YES/NO	YES		
Inactivity days	1 to 199	3	d (days)	

#### Drainage options (2/2)

parameter	range	default	UOM
Dilution drain time	50 to 200	100	%
Dilution drain freq.	50 to 200	100	%
Additional periodic cylinder fl	YES/NO	NO	
Time interval	1 to 120	24	h (hours)

### 8.5 Water conductivity

The supply water is normally monitored to avoid levels of high conductivity, and to determine the time the cylinder takes to reach steady operation.

parameter	range	def.	UOM
conductivity override	0* to 2000	0	uS/cm
conductivity limits			
pre-alarm (warning)	0 to (alarm value)	1000	uS/cm
alarm	(warning value) to 2000	1250	

\*: 0= deactivated

8.6 Supervisor

parameter	range	def.	UOM
identification number for BMS network	0 to 200	1	
Com. speed	1200, 2400, 4800, 9600, 19200	19200	Bps
Protocol	CAREL, MODBUS, LON, RS232, GSM(*), WINLOAD	CAREL	
Enable On/OFF from supervisor	YES/NO	NO	

(\*) By setting the GSM protocol, when alarms are activated the humidifier sends an SMS (short message service) to the mobile telephone number set.

-  **Important:** to send an SMS, the humidifier must be fitted with the electronic board code PCO100MDM0, the GSM modem kit code PLW0PGSM00, and a SIM card in the modem (see par. "GSM network connection" page 17).

"SMS" configuration procedure

- set the GSM protocol from the "Supervisor" screen (see "Supervisor" screen > "Protocol");
- press ENTER until the cursor is at the start of the screen;
- press the DOWN button and access the "SMS" screen;
- configure the "SMS" screen:

SMS		
parameter	range	default
text on mask send SMS	enter text(*)	CAREL HUMISTEAM
mobile number	enter mobile phone number (*)	-
modem status (display only)		
parameter	display	default
field	percentage of signal	-
alarm modem	NO/YES	-

(\*) Text characters:

A	B	C	D	E	F	G	H	I	J	K	L
M	N	O	P	Q	R	S	T	U	V	W	X
Y	Z	0	1	2	3	4	5	6	7	8	9
+	-	*	:	;	,	(	)	/	#	%	

Function buttons:

- UP or DOWN to select the characters;
- ENTER to save and move the cursor to the next character.

 **Important:** the humidifier only has one communication line (baud rate and protocol). When enabling SMS messages, a supervisory network can not be created (and vice-versa).

 **Important:**

- only use numeric characters;
- disable the PIN code on the SIM card;
- messages can only be sent in SMS format;
- the SMS messages are subject to the charges and conditions of the SIM card network operator.

CAREL declines all liability for the failure to send or receive SMS.

installer

user

service

## 9. MAINTENANCE MENU

 **Important:** the operations described in this menu must only be carried out by qualified personnel.

From the main screen press:

- PRG to access the main menu,
- DOWN to select the maintenance menu,
- ENTER,
- ENTER,
- UP or DOWN to enter the password "77",
- ENTER to confirm and access the maintenance menu.

Maintenance menu screens:

1. Reset configurations
2. System info
3. Manual procedure
4. Change cylinder
5. Alarm log

### 9.1 Reset configurations

Functions:

- save the set configuration,
- recall the saved configuration,
- display the type of humidifier,
- install the default parameters for the model of humidifier displayed.

parameter	range	UOM
save configurations	YES/NO	
recall configurations	YES/NO	
humidifier type	xxx Kg/h xxxV x-ph	kg/h, V, ph
install default values	YES/NO	

### 9.2 System info

Functions:

- display the code and version of the application installed;
- change the language;
- display the "select language" screen when the humidifier is started.

parameter	display/range
Bios	read-only
Boot	read-only
Code	read-only
Version	read-only
Language	Italian, English, German, French, Spanish
show language mask to unit start-up?	YES/NO

### 9.3 Manual procedure

 **Important:** these operations must only be performed by qualified personnel, incorrect use may cause serious damage.

These procedures are used to manually test the main functions and operations of the humidifier:

- closing of the contactor/contactors
- opening of the water fill valve/valves
- activation of the drain pump/pumps
- alarm relay
- activation of the dehumidifier contact

Manual procedure, cylinder	
parameter	display/range
manual procedure	Y/N
power contactor	ON/OFF
fill valve	ON/OFF
drain pump	ON/OFF
alarm relay	ON/OFF
dehumidif. contact	ON/OFF

In the models with two cylinders, there is a second screen for the second cylinder (with the same functions and procedures as the first).

### 9.4 Change cylinder

Complete the following procedure before changing the cylinder:

parameter	range
empty cylinder	YES/NO
reset cylinder lifetime counter	YES/NO
last replace (read only)	dd/mm/yy
flush new cylinder (*)	YES/NO

(\*) wash the new cylinder when replacing.

In the models with two cylinders, there is a second screen for the second cylinder (with the same functions and procedures as the first).

### 9.5 Alarm history

Recorded trace of the alarms (events) that have been activated. The humidifier memory can record up to 200 events (complete with description and date, press DOWN to scroll the list).

parameter	display
Alarm	event description
Time	hh:mm
Date	dd/mm/yy

## 10. TABLE OF ALARMS

When an alarm is activated, the alarm button starts flashing intermittently. In these conditions, pressing the alarm button once displays the type of alarm (and the code, in line with the CAREL humidifier standard).

In the case of potentially dangerous alarms, the controller automatically stops the production of steam. For some alarm events, the alarm relay is also activated at the same time as the signal (see the table below).

Once the causes of the alarm are no longer present, the humidifier and the

alarm relay output can be reset automatically or manually, according to the type of fault, while the message displayed is reset manually (see the table below). Even if no longer active, the alarm status continues to be displayed until the "reset display" button is pressed.

Active alarm states cannot be reset.

If more than one alarm is active, the display shows all the codes in sequence, after having pressed the alarm button once and then pressing the "UP" or "DOWN" button.

alarms displayed (2)= alarm relating to cylinder 2	meaning	cause	solution	reset	alarm relay	consequence
Alarm: EP Low Production (Cylinder 1(2) Off)	Low production alarm	excessive reduction in production	cylinder completely depleted or water with excessive foam. Perform maintenance on the cylinder	Manual	active	Stop production
Alarm: EF Lack of water Cylinder 1(2)	No water	no supply water	1. check that the supply hose from the mains to the humidifier and the internal hoses are not blocked or restricted and that there is sufficient pressure (0.1 to 0.8 MPa, 1 to 8 bar); 2. check the operation of the fill solenoid valve; 3. check that the steam outlet is not operating with excessive backpressure, preventing the flow of water into the cylinder by gravity; 4. check that the steam outlet hose is not restricted and that there are no pockets of condensate	Automatic (automatic water return procedure) (see par. 4.4.10)  Manual	active	Stop production
Alarm: Ed Drain alarm (Cylinder 1(2) Off)	Drain alarm	drain malfunction	check the water drain circuits and the correct operation of the electric drain pump, and check the condition of the filter inside the cylinder	Manual	active	Stop production
Alarm: EL Low current (Cylinder 1(2) Off)	Low current alarm	power not available; when the unit is activated no steam is produced	with the unit off and disconnected from the mains, check the electrical connections inside	Manual	active	Stop production
Alarm: EH High current (Cylinder 1(2) Off)	High current alarm	excess current in the electrodes; probable fault with the electrodes or water temporarily too conductive (especially when restarting after a short stop)	1. check the operation of the electric drain pump; 2. check the seal of the supply solenoid valve when not energized; 3. drain some of the water and restart. 4. check for bridges between the electrodes. 5. cylinder replacement and/or maintenance	Manual	active	Stop production
Alarm: EC High conductivity (Cylinders Off)	High conductivity alarm	high conductivity of the supply water	1. check the limit threshold set; 2. switch the unit off and clean the electrodes that measure the conductivity of the water; if the problem persists, change the origin of the supply water or use a suitable treatment system (partial demineralization).  N.B.: the problem is not resolved by softening the supply water.	Manual	active	Stop production
Warning: Ec High conductivity	High supply water conductivity pre-alarm	high water conductivity alarm warning	1. check the conductivity of the supply water, if necessary use a suitable treatment system.  N.B.: the problem is not resolved by softening the supply water	Automatic	not active	signal only
Warning: E> High humidity	Main probe pre-alarm	high humidity in the room (high temp. if the temperature probe is used)	check the operation of the probe and the upper limit set by parameter	Automatic	not active	signal only.
Warning: E_ Low humidity	Main probe low humidity pre-alarm	low humidity in the room (low temp. if the temperature probe used)	check the operation of the probe and the lower limit set by parameter	Automatic	not active	signal only

Warning: E= High humidity limit probe	Limit probe humidity warning	limit probe high humidity reading	check the operation of the limit probe	Automatic	not active	signal only.
Alarm: E3 Main probe fault or offline	Main probe disconnected alarm	main probe not connected	check the connection of the probe, and the setting of the parameters (probe type and signal type)	Automatic	active	Stop production (also for slave units)
Alarm: E4 Limit probe fault or offline	Limit probe disconnected alarm	limit probe not connected	check the connection of the probe, and the setting of the parameters (probe type and signal type)	Automatic	not active	signal only
Warning: EA Foam Cylinder 1(2)	Foam alarm	excessive foam in the cylinder when boiling	1. flush the water supply lines; 2. clean the cylinder, make sure a softener is not used (if so, use another source of water or reduce the softening).	Manual	not active	signal only
Warning: CP Pre-exhaustion cylinder 1(2)	Cylinder being depleted	signal that the cylinder life is ending	perform maintenance and/or replace the cylinder	Manual	not active	signal only
Alarm: EU Cylinder 1(2) full	Cylinder full	signal that the cylinder is full with the unit off	with the unit off: 1. check for any leaks from the fill solenoid valve or the condensate return from the hose, check that the level sensors are clean	Manual	active	Stop production
Warning: CL Exhaustion cylinder 1(2)	Cylinder depleted	cylinder depleted signal	perform maintenance and/or replace the cylinder	Manual	active	Stop production
Warning: CY Cylinder 1(2) Maintenance Recommended	Maintenance recommended	cylinder good operating hour limit exceeded	perform maintenance and/or replace the cylinder	Manual (reset counter. See Maintenance menu)	not active	signal only.
Alarm: Mn Cylinder 1(2) Maintenance Mandatory	Maintenance required	maximum cylinder operating hours exceeded	replace the cylinder	Manual (reset counter. See Maintenance menu)	active	Stop production
Clock Board Fault	Clock error	backup battery completely discharged or general problem with the clock	replace the controller	Manual	not active	signal only

The alarm button performs a number of actions, depending on how many times it is pressed.

Action/Pressing the button	Effect
first time	display the alarm code; if more than one alarm is active at the same time, the screen shows NEXT, and the sequence of alarm codes can be scrolled using the DOWN button.
second time	the cause of the alarm has been resolved, the alarm is no longer displayed, the corresponding relay is deactivated and the display shows: NO ACTIVE ALARMS
third time	return to the main screen

Tab. 7.b

If the causes of the alarm persist, the alarm is not reset.

# 11. MAINTENANCE AND SPARE PARTS

## 11.1 Spare parts for models UE001 to UE018

installer

user

service

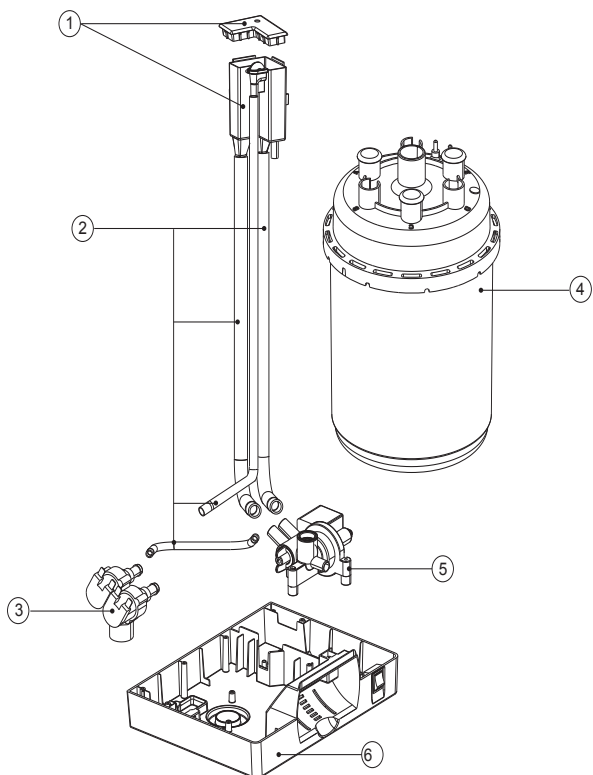

Fig. 11.a

Key

- 1 fill tank
- 2 internal tubing kit
- 3 fill solenoid and drain tempering valve kit
- 4 cylinder
- 5 manifold with drain pump
- 6 plastic base
- 7 plastic humidifier top
- 8 TAM (transformer for measuring the current)
- 9 transformer
- 10 contactor
- 11 fuse carrier
- 12 electronic controller
- 13 power terminals
- 14 plastic base
- 15 switch
- 16 terminal with display

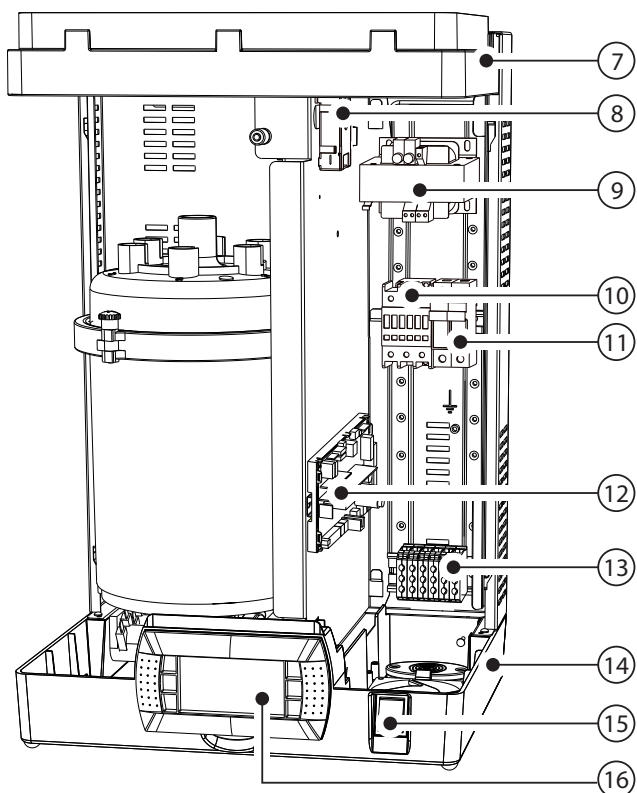

Fig. 11.b

Table of water circuit, electrical and electronic spare parts, UE001 to 018

	UE001	UE003	spare part code						position	fig.	
			UE005		UE008	UE009	UE010	UE015			UE018
			208-230-460-575 3ph	208-230 1ph							
<b>Water circuit</b>											
Fill tank + conductivity meter	UEKVASC100						1	11.a			
fill solenoid and drain tempering valve kit	KITFD11206			KITFD11211			3	11.a			
Internal tubing kit	UEKT20000S			UEKT20000M			2	11.a			
Plastic humidifier base	UEKBOTTOM0						6	11.a			
Plastic humidifier top	UEKTOP0000						7	11.a			
Assembled f/d manifold + 230V pump	UEKDRAIN02						5	11.a			
<b>Electrical and electronics</b>											
Display terminal	HCT1EXW000						16	11.b			
TAM (current transformer)	UEKTAM0000						8	11.b			
Contacto	UEKCONT100		UEKCONT200				10	11.b			
Power transformer: 208-230-460-575/24 V	UEKTR30000						9	11.b			
Electronic controller <sup>(1)</sup>	UEXxxv0000 <sup>(2)</sup>						12	11.b			
Fuse carrier (F1,F2)	URKFH10000						11	11.b			
Fuse carrier (F3)	UEKFH10000						11	11.b			
F1 - F2 power fuses	URKFUSE100						-	see electrical draw			
F4 Transformer secondary fuse	URKFUSE500						-	see electrical draw			
F3 Pump fuse	UEKFUSE200						-	see electrical draw			
Connection cable between terminal and electronic controller	S90CONN002						-				

Tab. 11.a

<sup>(1)</sup>To make an order specify the complete product code and the serial number of your humidifier.

<sup>(2)</sup> XX: kg/h (01...90) and (A3 for 130)  
v: voltage

 For items not listed, please refer to CAREL, your local branch or agent.

Table of spare part codes, single-phase cylinders UE001 to 009, electrode and gasket kit

Model	UE001	UE003	UE005	UE009	
STANDARD disposable cylinders	208/230 Vac 1~, conductivity 350 to 1250 µS/cm	BLOS1F00H2	BLOS1F00H2	BLOS2E00H2	BLOS3F00H2
SPECIAL disposable cylinders	208/230 Vac 1~, conductivity 75 to 350 µS/cm	BLOS1E00H2	BLOS1E00H2	BLOS2E00H2	BLOS3E00H2
SPECIAL openable cylinders	208/230 Vac 1~, conductivity 75 to 350 µS/cm	BLCS1E00W2	BLCS1E00W2	BLCS2E00W2	BLCS3E00W2
	208/230 Vac 1~, conductivity 350 to 1250 µS/cm	BLCS1F00W2	BLCS1F00W2	BLCS2E00W2	BLCS3F00W2
Electrode and gasket kit	208/230 Vac 1~, conductivity 75 to 350 µS/cm	KITBLCS1E2	KITBLCS2E2	KITBLCS2E2	KITBLCS3E2
	208/230 Vac 1~, conductivity 350 to 1250 µS/cm	KITBLCS1F2	KITBLCS2E2	KITBLCS2E2	KITBLCS3F2
Filter gasket kit		KITBLC1FG0	KITBLC2FG0	KITBLC2FG0	KITBLC3FG0

Tab. 11.b

installer

user

service

Table of spare part codes, three-phase cylinders UE003 to 018, electrode and gasket kit

Model		UE003	UE005	UE008	UE010	UE015	UE018
STANDARD disposable cylinders	208/230 VAC 3~, conductivity 350 to 1250 µS/cm	BL0T1B00H2	BL0T2A00H2	BL0T2A00H2	BL0T3A00H2	BL0T3A00H2	--
	460 VAC 3~, conductivity 350 to 750 µS/cm	BL0T1D00H2	BL0T2D00H2	BL0T2D00H2	BL0T3D00H2	BL0T3D00H2	BL0T3D00H2
	575 VAC 3~, conductivity 350 to 750 µS/cm		BL0T2D00H2	BL0T2D00H2	BL0T3D00H2	BL0T3D00H2	BL0T3D00H2
SPECIAL disposable cylinders	208/230 VAC 3~, conductivity 75-350 µS/cm	BL0T1A00H2	BL0T2A00H2	BL0T2A00H2	BL0T3A00H2	BL0T3A00H2	--
	460 VAC 3~, conductivity 75 to 350 µS/cm	BL0T1B00H2	BL0T2C00H2	BL0T2C00H2	BL0T3C00H2	BL0T3C00H2	BL0T3C00H2
	460 VAC 3~, conductivity 750 to 1250 µS/cm	BL0T1D00H2	BL0T2D00H2	BL0T2D00H2	BL0T3D00H2	BL0T3D00H2	BL0T3D00H2
	575 VAC 3~, conductivity 75 to 350 µS/cm		BL0T2C00H2	BL0T2C00H2	BL0T3C00H2	BL0T3C00H2	BL0T3C00H2
	575 VAC 3~, conductivity 750 to 1250 µS/cm		BL0T2D00H2	BL0T2D00H2	BL0T3D00H2	BL0T3D00H2	BL0T3D00H2
SPECIAL openable cylinders	208/230 VAC 3~, conductivity 75-350 µS/cm	BLCT1A00W2	BLCT2A00W2	BLCT2A00W2	BLCT3A00W2	BLCT3A00W2	--
	460 VAC 3~, conductivity 75 to 350 µS/cm	BLCT1B00W2	BLCT2C00W2	BLCT2C00W2	BLCT3C00W2	BLCT3C00W2	BLCT3C00W2
	460 VAC 3~, conductivity 350 to 750 µS/cm	BLCT1D00W2	BLCT2D00W2	BLCT2D00W2	BLCT3D00W2	BLCT3D00W2	BLCT3D00W2
	460 VAC 3~, conductivity 750 to 1250 µS/cm	BLCT1D00W2	BLCT2D00W2	BLCT2D00W2	BLCT3D00W2	BLCT3D00W2	BLCT3D00W2
	575 VAC 3~, conductivity 75 to 350 µS/cm		BLCT2C00W2	BLCT2C00W2	BLCT3C00W2	BLCT3C00W2	BLCT3C00W2
	575 VAC 3~, conductivity 350 to 750 µS/cm		BLCT2D00W2	BLCT2D00W2	BLCT3D00W2	BLCT3D00W2	BLCT3D00W2
	575 VAC 3~, conductivity 750 to 1250 µS/cm		BLCT2D00W2	BLCT2D00W2	BLCT3D00W2	BLCT3D00W2	BLCT3D00W2
	575 VAC 3~, conductivity 750 to 1250 µS/cm		BLCT2D00W2	BLCT2D00W2	BLCT3D00W2	BLCT3D00W2	BLCT3D00W2
Electrode and gasket kit	Electrode kit 208/230 Vac 3~, 75/350 µS/cm	KITBLCT1A2	KITBLCT2A2	KITBLCT2A2	KITBLCT3A2	KITBLCT3A2	--
	Electrode kit 208/230 Vac 3~, 350/1250 µS/cm	KITBLCT1B2	KITBLCT2A2	KITBLCT2A2	KITBLCT3A2	KITBLCT3A2	--
	Electrode kit 460 Vac 3~, 75/350 µS/cm	KITBLCT1B2	KITBLCT2C2	KITBLCT2C2	KITBLCT3C2	KITBLCT3C2	KITBLCT3C2
	Electrode kit 460 Vac 3~, 350/750 µS/cm	KITBLCT1D2	KITBLCT2D2	KITBLCT2D2	KITBLCT3D2	KITBLCT3D2	KITBLCT3D2
	Electrode kit 460 Vac 3~, 750/1250 µS/cm	KITBLCT1D2	KITBLCT2D2	KITBLCT2D2	KITBLCT3D2	KITBLCT3D2	KITBLCT3D2
	Filter gasket kit	KITBLC1FG0	KITBLC2FG0	KITBLC2FG0	KITBLC3FG0	KITBLC3FG0	KITBLC3FG0
	575 VAC 3~, conductivity 75 to 350 µS/cm		KITBLCT2C2	KITBLCT2C2	KITBLCT3C2	KITBLCT3C2	KITBLCT3C2
	575 VAC 3~, conductivity 350 to 750 µS/cm		KITBLCT2D2	KITBLCT2D2	KITBLCT3D2	KITBLCT3D2	KITBLCT3D2
575 VAC 3~, conductivity 750 to 1250 µS/cm		KITBLCT2D2	KITBLCT2D2	KITBLCT3D2	KITBLCT3D2	KITBLCT3D2	

Tab. 11.c

installer

user

service

11.2 Spare parts for models UE025 to UE065

Key:

- 1 drain circuit
- 2 fill solenoid valve kit
- 3 internal tubing kit
- 4 conductivity meter
- 5 drain pump kit
- 6 manifold
- 7 drain pump hose
- 8 cylinder
- 9 TAM (transformer for measuring the current)
- 10 contactor
- 11 transformer
- 12 pump control relay
- 13 fuse carrier
- 14 electronic controller
- 15 power terminals
- 16 cable clamp- 17 switch
- 18 terminal with liquid crystal display (fitted on the cover of the electrical compartment)
- 19 kit outlet connector steam (only in the UE045(208-230Vac and UE065)
- 20 drain tempering valve
- 21 liquid level cutoff (only in the UE045(208-230Vac and UE065)

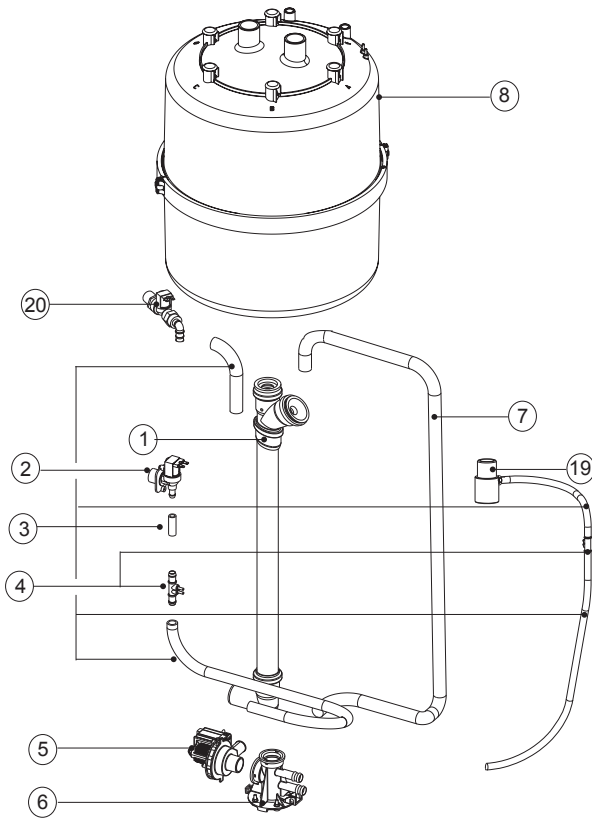

Fig. 11.c

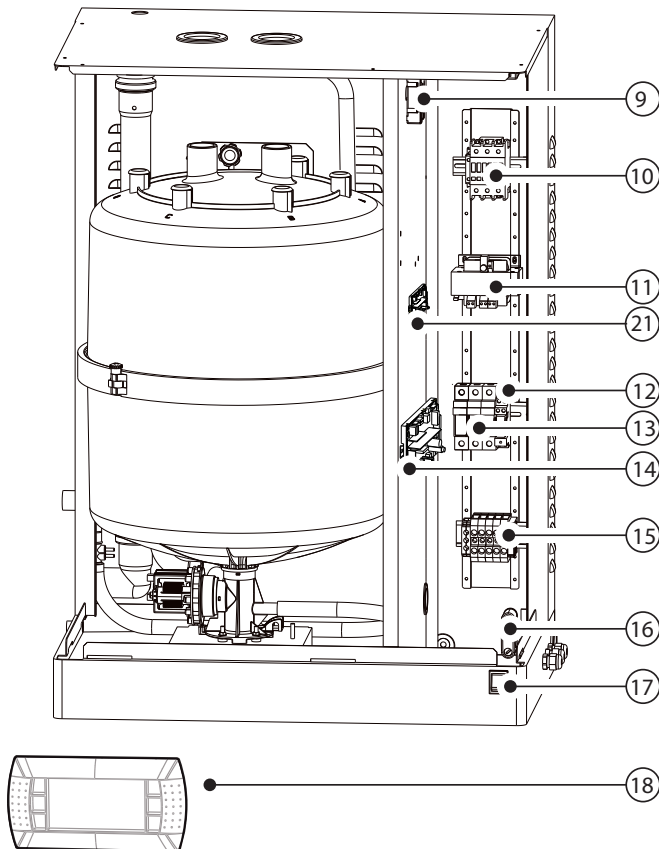

Fig. 11.d

Table of water circuit, electrical and electronic spare parts, UE025 to UE065

description	spare part code						position	fig.	
	UE025		UE035		UE045				UE065
	208-230 V	460-575 V	208-230V	460-575V	460 -575 V	208-230 V			
<b>Water circuit</b>									
Drain pump hose				UEKDH0000			7	11.c	
Manifold			UEKCOLL000			UEKCOLL100	6	11.c	
Drain pump kit				KITPSE0000			5	11.c	
Internal tubing kit			UEKT20000L			UEKT2000XL	3	11.c	
Kit double check valve				FWHDCV0000			-		
Conductivity meter kit				KITCN00000			4	11.c	
Fill solenoid valve kit			KITVC10058			KITVC10070	2	11.c	
Drain circuit			UEKDC00000			UEKDC10000	1	11.c	
kit outlet connector steam						UEKCS00000	19	11.c	
kit drain tempering				KITDT10030			20	11.c	
<b>Electrical and electronics</b>									
Display terminal				HCT1EXF000			18	11.d	
TAM (current transformer)				UEKTAM0000			9	11.d	
Contactor	URKCONT300	UEKCONT200	URKCONT300	URKCONT400		URKCONT300	10		
Power transformer: 208-230-460-575-24V				UEKTR40000			11	11.d	
Electronic controller <sup>(1)</sup>				UEXxxv0000 <sup>(2)</sup>			14	11.d	
Fuse carrier				URKFH20000			13	11.d	
Pump control relay				UEKRD00000			12	11.d	
F1 - F2 230 to 208Vac power fuses				URKFUSE200			-	see electrical draw	
F1 - F2 460 to 575Vac power fuses				URKFUSE100			-	see electrical draw	
F3 Pump fuse				URKFUSE400			-	see electrical draw	
F4 Transformer secondary fuse				URKFUSE500			-	see electrical draw	
Connection cable between terminal and electronic controller				S90CONN002			-		
kit liquid level switch						UEKLL00000	UEKLL00000	-	see electrical draw

Tab. 11.d

<sup>(1)</sup> To make an order specify the complete product code and the serial number of your humidifier.

<sup>(2)</sup> XX: kg/h (01...90) and (A3 for 130)  
v: voltage

 For items not listed, please refer to CAREL, your local branch or agent.

installer

user

service

Table of spare parts for standard and special cylinders UE025 to UE065

Description		UE025	UE035	UE045	UE065
STANDARD disposable cylinders	208V 3ph cylinder, conductivity 350 to 1250 μS/cm	BL0T4C00H2	BL0T4B00H2	BL0T5A00H1	-
	230V 3ph cylinder, conductivity 350 to 1250 μS/cm	BL0T4C00H2	BL0T4B00H2	BL0T5B00H0	
	460V 3ph cylinder, conductivity 350 to 1250 μS/cm	BL0T4D00H2	BL0T4D00H2	BL0T4D00H2	BL0T5D00H0
	575V 3ph cylinder, conductivity 350 to 1250 μS/cm	BL0T4D00H2	BL0T4D00H2	BL0T4D00H2	BL0T5D00H0
SPECIAL disposable cylinders	208V 3ph cylinder, conductivity 75 to 350 μS/cm	BL0T4B00H2	BL0T4B00H2	BL0T5A00H1	--
	230V 3ph cylinder, conductivity 75 to 350 μS/cm	BL0T4B00H2	BL0T4B00H2	BL0T5A00H1	
	460V 3ph cylinder, conductivity 75 to 350 μS/cm	BL0T4D00H2	BL0T4C00H2	BL0T4C00H2	BL0T5C00H0
	575V 3ph cylinder, conductivity 75 to 350 μS/cm	BL0T4D00H2	BL0T4D00H2	BL0T4D00H2	BL0T5C00H0
SPECIAL openable cylinders	208V 3ph cylinder, conductivity 75 to 350 μS/cm	BLCT4B00W2	BLCT4B00W2	BLCT5A00W1	--
	230V 3ph cylinder, conductivity 75 to 350 μS/cm	BLCT4B00W2	BLCT4B00W2	BLCT5A00W1	
	208V 3ph cylinder, conductivity 350 to 1250 μS/cm	BLCT4C00W2	BLCT4B00W2	BLCT5A00W1	--
	230V 3ph cylinder, conductivity 350 to 1250 μS/cm	BLCT4C00W2	BLCT4B00W2	BLCT5B00W0	
	460V 3ph cylinder, conductivity 75 to 350 μS/cm	BLCT4D00W2	BLCT4C00W2	BLCT4C00W2	BLCT5C00W0
	460V 3ph cylinder, conductivity 350 to 1250 μS/cm	BLCT4D00W2	BLCT4D00W2	BLCT4D00W2	BLCT5C00W0
	575V 3ph cylinder, conductivity 75 to 350 μS/cm	BLCT4D00W2	BLCT4D00W2	BLCT4D00W2	BLCT5C00W0
	575V 3ph cylinder, conductivity 350 to 1250 μS/cm	BLCT4D00W2	BLCT4D00W2	BLCT4D00W2	BLCT5D00W0
	Electrode and gasket kit	208V 3ph cylinder, conductivity 75 to 350 μS/cm	KITBLCT4B2	KITBLCT4B2	KITBLCT5A0
208V 3ph cylinder, conductivity 350 to 1250 μS/cm		KITBLCT4C2	KITBLCT4B2	KITBLCT5A0	--
230V 3ph cylinder, conductivity 75 to 350 μS/cm		KITBLCT4B2	KITBLCT4B2	KITBLCT5A0	
230V 3ph cylinder, conductivity 350 to 1250 μS/cm		KITBLCT4C2	KITBLCT4B2	KITBLCT5B0	--
460V 3ph cylinder, conductivity 75 to 350 μS/cm		KITBLCT4D2	KITBLCT4C2	KITBLCT4C2	KITBLCT5C0
460V 3ph cylinder, conductivity 350 to 1250 μS/cm		KITBLCT4D2	KITBLCT4D2	KITBLCT4D2	KITBLCT5D0
575V 3ph cylinder, conductivity 75 to 350 μS/cm		KITBLCT4D2	KITBLCT4D2	KITBLCT4D2	KITBLCT5C0
575V 3ph cylinder, conductivity 350 to 1250 μS/cm		KITBLCT4D2	KITBLCT4D2	KITBLCT4D2	KITBLCT5D0
Gasket and filter kit	KITBLC4FG0	KITBLC4FG0	KITBLC4FG0	KITBLC5FG0	

**Tab. 11.e**

installer

user

service

11.3 Spare parts for models UE090 to UE130

installer

user

service

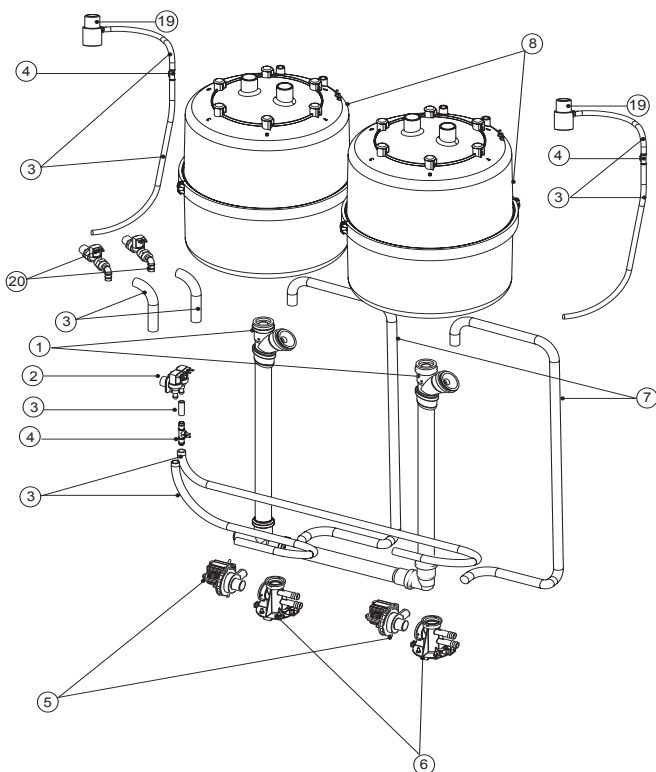

Key:

- 1 drain circuit
- 2 fill solenoid valve kit
- 3 internal tubing kit
- 4 conductivity meter
- 5 drain pump kit
- 6 manifold
- 7 drain pump hose
- 8 cylinder
- 9 TAM (transformer for measuring the current)
- 10 contactor
- 11 transformer
- 12 pump control relay
- 13 fuse carrier
- 14 electronic controller
- 15 power terminals
- 16 cable clamp
- 17 switch
- 18 terminal with liquid crystal display (fitted on the cover of the electrical compartment)
- 19 kit outlet connector steam
- 20 drain tempering valve
- 21 liquid level safety switch

Fig. 11.e

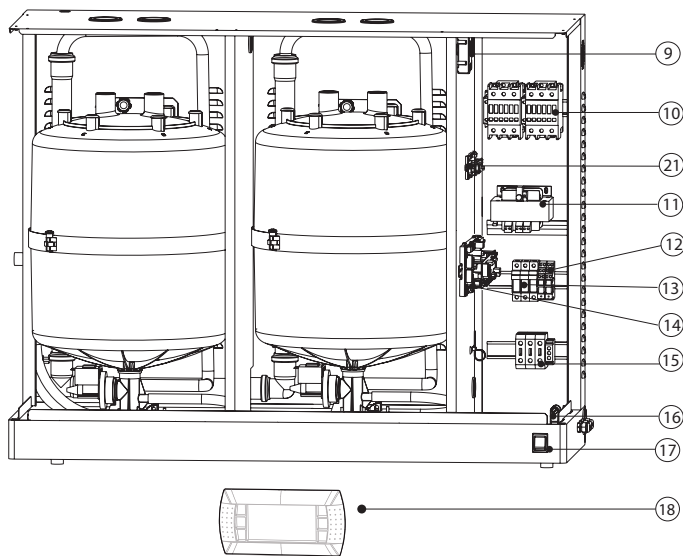

Fig. 11.f

Table of water circuit, electrical and electronic spare parts, UE090 to UE130

description	spare part code		position	fig.
	UE090	UE130		
<b>Water circuit</b>				
Drain pump hose	UEKDH00000		7	11.e
Manifold	UEKCOLL100		6	11.e
Drain pump kit	KITPSE0000		5	11.e
Internal tubing kit	UEKT200XXL		3	11.e
Double check valve kit	FWHDCV0000		-	
Conductivity meter kit	KITCN00000		4	11.e
Fill solenoid valve kit	KITVC10140		2	11.e
Drain circuit	UEKDC20000		1	11.e
kit drain tempering	KITDT10030		20	11.e
kit outlet connector steam	UEKCS00000		19	11.e
<b>Electrical and electronics</b>				
Display terminal	HCT1EXF000		18	11.f
TAM (current transformer)	UEKTAM0000		9	11.f
Contactora	URKCONT300		10	11.f
Power transformer	UEKTR20000		11	11.f
Electronic controller <sup>(1)</sup>	UEXxxv0000 <sup>(2)</sup>		14	11.f
Fuse carrier	URKFH20000		13	11.f
Pump control relay	UEKRD00000		12	11.f
F1 - F2 power fuses	URKFUSE200		-	see electrical draw
F3 Pump fuse	URKFUSE300		-	see electrical draw
F4 Transformer secondary fuse	UEKFUSE400		-	see electrical draw
kit liquid level switch	UEKLL00000		-	see electrical draw
Connection cable between terminal and electronic controller	S90CONN002		-	

**Tab. 11.f**

<sup>(1)</sup> To make an order specify the complete product code and the serial number of your humidifier.

<sup>(2)</sup> XX: kg/h (01...90) and (A3 for 130)  
v: voltage



For items not listed, please refer to CAREL, your local branch or agent

Table of spare parts for standard and special cylinders UE090 to UE130

Description		UE090	UE130
STANDARD disposable cylinders	460V 3ph cylinder, conductivity 350 to 1250 µS/cm	BL0T4D00H2	BL0T5D00H0
	575V 3ph cylinder, conductivity 350 to 1250 µS/cm	BL0T4D00H2	BL0T5D00H0
SPECIAL disposable cylinders	460V 3ph cylinder, conductivity 75 to 350 µS/cm	BL0T4C00H2	BL0T5C00H0
	575V 3ph cylinder, conductivity 75 to 350 µS/cm	BL0T4D00H2	BL0T5D00H0
SPECIAL openable cylinder	460V 3ph cylinder, conductivity 75 to 350 µS/cm	BLCT4C00W2	BLCT5C00W0
	460V 3ph cylinder, conductivity 350 to 1250 µS/cm	BLCT4D00W2	BLCT5D00W0
	575V 3ph cylinder, conductivity 75 to 350 µS/cm	BLCT4D00W2	BLCT5D00W0
	575V 3ph cylinder, conductivity 350 to 1250 µS/cm	BLCT4C00W2	BLCT5C00W0
Electrode and gasket kit	460V 3ph cylinder, conductivity 75 to 350 µS/cm	KITBLCT4C2	KITBLCT5C0
	460V 3ph cylinder, conductivity 350 to 1250 µS/cm	KITBLCT4D2	KITBLCT5D0
	575V 3ph cylinder, conductivity 75 to 350 µS/cm	KITBLCT4D2	KITBLCT4D0
	575V 3ph cylinder, conductivity 350 to 1250 µS/cm	KITBLCT4D2	KITBLCT5D0
Gasket and filter kit		KITBLC4FG0	KITBLC5FG0

**Tab. 11.g**

## 11.4 Cleaning and maintenance of the cylinder

### Replacement

**Important:** the cylinder must be only be replaced by qualified personnel, and with the humidifier disconnected from the power supply.

In normal conditions, the **disposable cylinders should be replaced after one year** (or 2500 hours of operation, if cleaned periodically), while the **openable cylinders last 5 years** (or 10,000 hours of operation, if cleaned periodically). They must be replaced immediately – even before the specified intervals – if any anomalies occur. For example, when the lime scale inside the cylinder prevents the correct flow of electric current.

### Replacement procedure:

1. empty all the water (cylinder replacement procedure, see maintenance menu);
2. turn off the humidifier (switch "0"), and open the mains disconnect switch on the power supply (safety procedure);
3. wait for the humidifier and the cylinder to cool down;
4. remove the front cover;
5. disconnect the electrical cables from the cylinder;
6. release the cylinder from the locking device and lift it to remove it;
7. insert the new cylinder (make sure that the model and the power supply of the new cylinder correspond to the rated data);
8. fasten the cylinder;
9. reconnect the electrical cables to the cylinder;
10. replace the front cover;
11. switch on the humidifier;
12. reset cylinder operating hour counter (see maintenance menu);
13. Activate the wash new cylinder procedure (see maintenance menu).

## 11.5 Mechanically draining the water in the cylinder

Drain due to gravity without activating the humidifier, recommended if:

- humidifier decommissioned;
- to empty the cylinder without switching the humidifier on.

### Mechanical drain:

- make sure that the humidifier is not powered;
- remove the cover (see page 8);
- activate the mechanical device under the cylinder (see the figure below).

Models UE001 to  
UE018

Models UE025 to  
UE45(460-575V)

Models UE065(460-575V),  
UE045(208-230V) to  
UE130

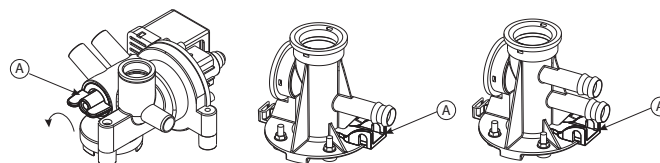

Fig. 11.g

### Periodical checks

- **After one hour** of operation: check for any significant water leaks.
- **Every 15 days** or no more than 300 operating hours: check operation, the absence of significant water leaks, the general conditions of the casing. Check that during operation there are no arcs or sparks between the electrodes.
- **Every 3 months** or no more than 1000 operating hours:
  - disposable cylinders: check operation, the absence of significant water leaks and if necessary replace the cylinder;
  - openable cylinders: if there are significantly blackened areas, check the deposits on the electrodes and clean them, using the specific electrode and gasket kit.
- **Every year** or no more than 2500 operating hours:
  - disposable cylinders: replace;
  - openable cylinders: if there are significantly blackened areas, check the deposits on the electrodes and clean them, using the specific electrode and gasket kit.
- **After 5 years** or no more than 10,000 operating hours: replace the openable cylinder.

After extended operation, or when using water rich in salts, the solid deposits that naturally form on the electrodes may grow until attaching to the inside wall of the cylinder. If these deposits are conductive the heat generated may overheat the plastic until it melts, with the risk of very hot water being released.



**Important:** In the event of water leaks, disconnect the power supply from the humidifier as the water may conduct electricity.

### 11.6 Cylinder connection

Three-phase models UE025 to UE130

production (kg/h)	conductivity (µS/cm)	power supply (V)	
		208-230	460-575
25	75/350 µS/cm	A	B
	350/1250 µS/cm	B	B
35	75/350 µS/cm	A	B
	350/1250 µS/cm	A	B
45	75/350 µS/cm	A	B
	350/1250 µS/cm	A	B
65	75/350 µS/cm	/	B
	350/1250 µS/cm	/	B
90	75/350 µS/cm	/	B
	350/1250 µS/cm	/	B
130	75/350 µS/cm	/	B
	350/1250 µS/cm	/	B

Tab. 11.h

The cable ends must be tightened with the top nut to 3 Newton · m (27 lbf·in). (units with BL\*T5\* cylinder only)

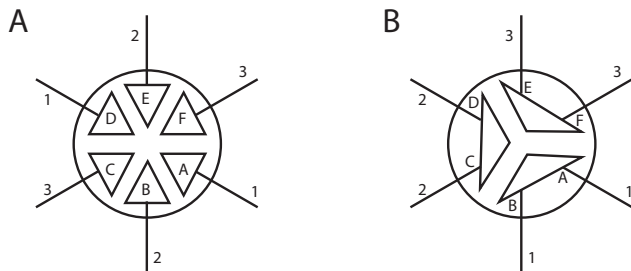

Three-phase and single-phase models UE01 to UE018

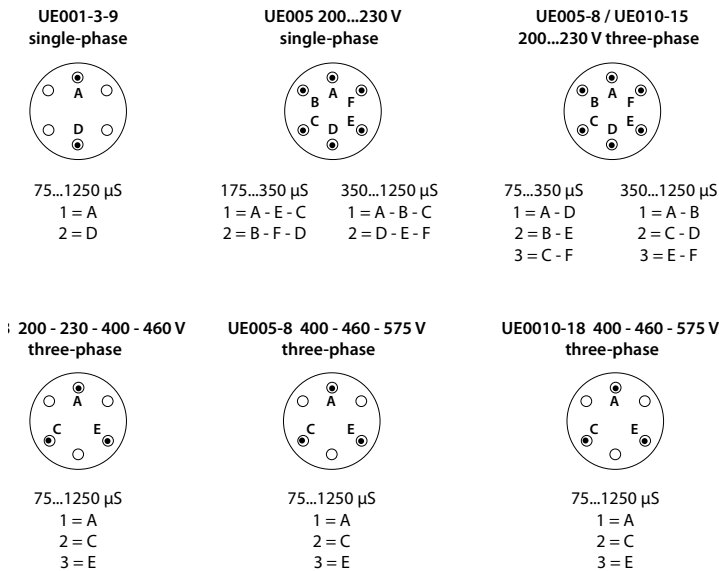

Fig. 11.h

### 11.7 Cleaning and maintenance of the other components

**Important:**

- when cleaning plastic components do not use detergents or solvents;
- scale can be removed using a solution of 20% acetic acid and then rinsing with water.

Maintenance checks on other components:

- fill solenoid valve. After having disconnected the cables and the tubing, remove the solenoid valve and make sure the inlet filter is clean; if necessary, clean with water and a soft brush;
- manifold with drain pump. Check that there are no solid residues in the cylinder attachment, remove any impurities. Check that the gasket (o-ring) is not damaged or cracked, replace if necessary. Check that there are no solid residues in the drain hose;
- drain pump. Disconnect the power supply, remove the pump and clean any impurities. Clean the tank of any deposits and check that the water flows freely from the tank to the drain (corresponding to the drain pump);
- NOTE: Make sure the drain tempering hose is extended down into the drain collar so that it is flush with the bottom of the collar.
- WARNING: Not extending hose far enough may cause water to back up into the bottom of the humidifier.
- fill tank. Check that there are no obstructions or solid particles and that the conductivity measuring electrodes are clean, remove any impurities and rinse;
- internal tubing kit. Check that the pipes and hoses are free and clear of impurities, remove any impurities and rinse.
- Important:** after having replaced or checked the water circuit, make sure that the connections are tight. Restart the unit and run a number of fill and drain cycles (from 2 to 4), after which, applying the safety procedure, check for any water leaks.

Fuses in the auxiliary circuits

Fuses	UE001 to 018	UE 025 to 065 (460-575V)	UE025-045 (208-230V)	UE 090 to 130
F1. F2	1 A fast-blow, 10.3x38	1 A fast-blow, 10.3x38	2 A fast-blow, 10.3x38	2 A fast-blow, 10.3x38
F3	1 A fast-blow, 10.3x38	1 A fast-blow, 10.3x38	1 A fast-blow, 10.3x38	1 A fast-blow, 10.3x38
F4	2.5 A T slow-blow 5x20 ceramic	2.5 A T slow-blow 5x20 ceramic	2.5 A T slow-blow 5x20 ceramic	4 A T slow-blow 5x20 in ceramic

Tab. 11.i

# 12. WIRING DIAGRAMS

## 12.1 Diagram of single-phase models UE001 to UE009(208-230V)

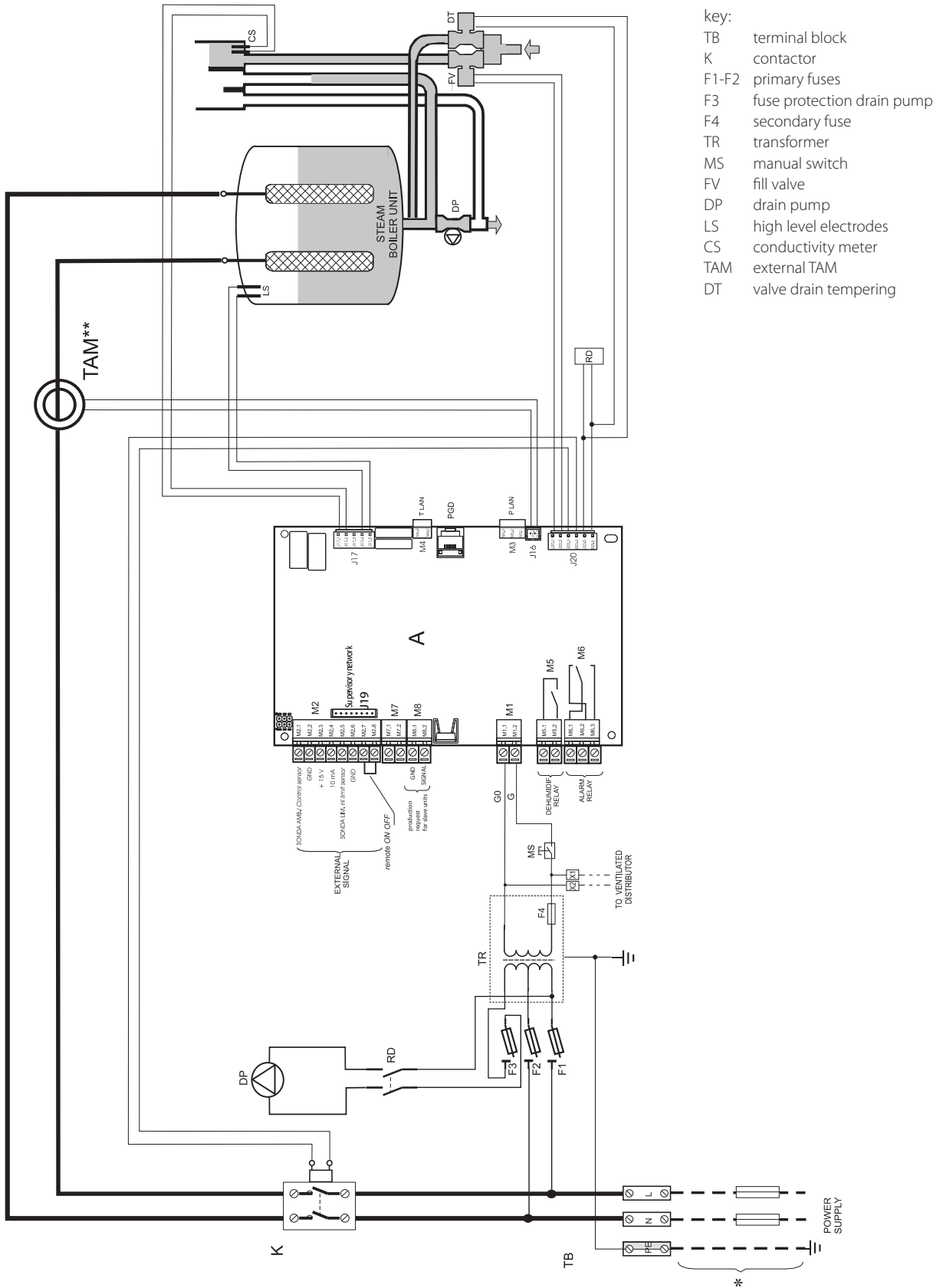

(\*\*) Attention: for TAM configurations and connections see par. 13.1

12.2 Diagram of three-phase models UE003 to UE018 (208-230-460-575V)

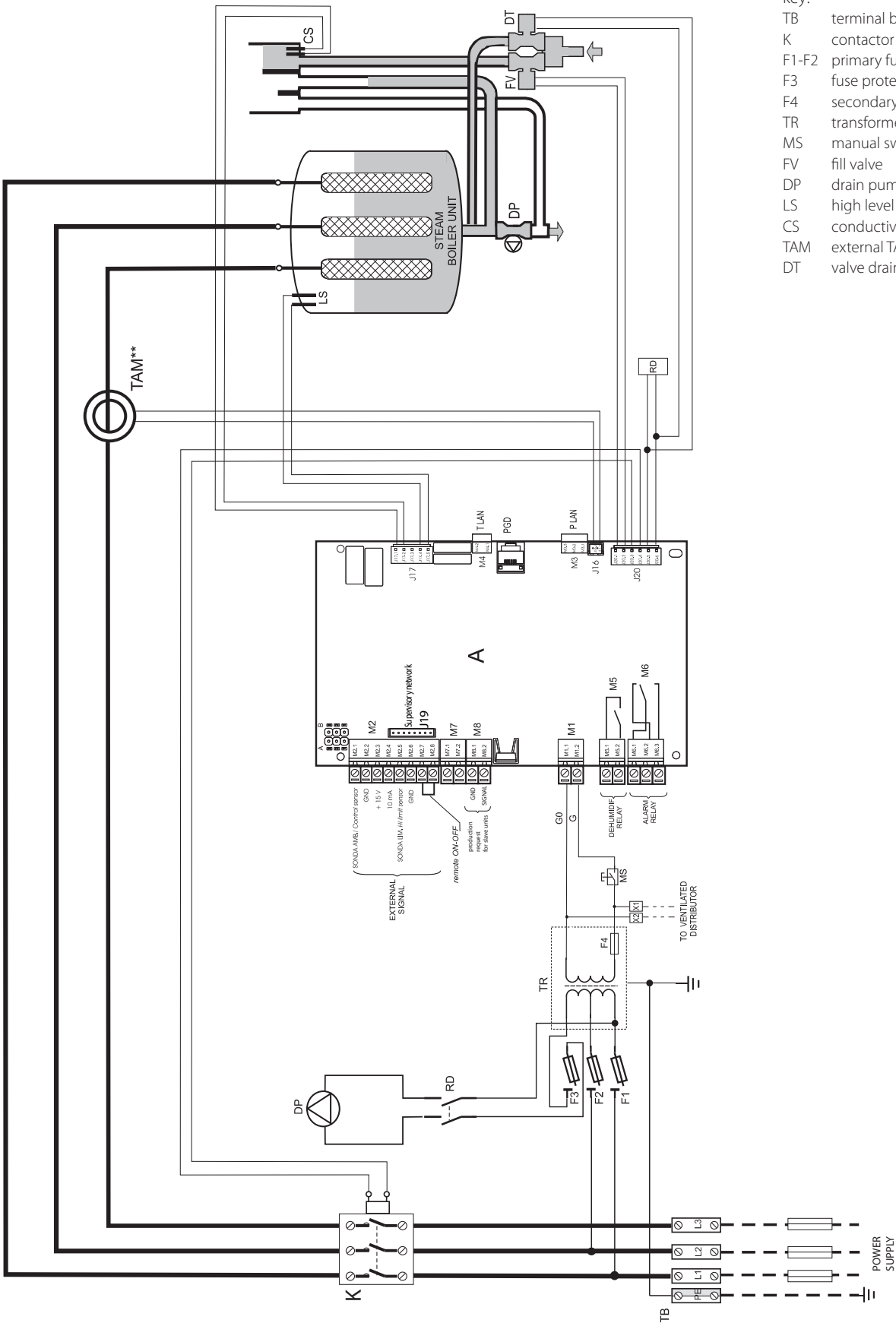

- key:
- TB terminal block
  - K contactor
  - F1-F2 primary fuses
  - F3 fuse protection drain pump
  - F4 secondary fuse
  - TR transformer
  - MS manual switch
  - FV fill valve
  - DP drain pump
  - LS high level electrodes
  - CS conductivity meter
  - TAM external TAM
  - DT valve drain tempering

installer

user

service

12.3 Diagram of three-phase models UE025(208-230-460-575V), UE35(208-230-460-575V) and UE045(460-575V)

installer

user

service

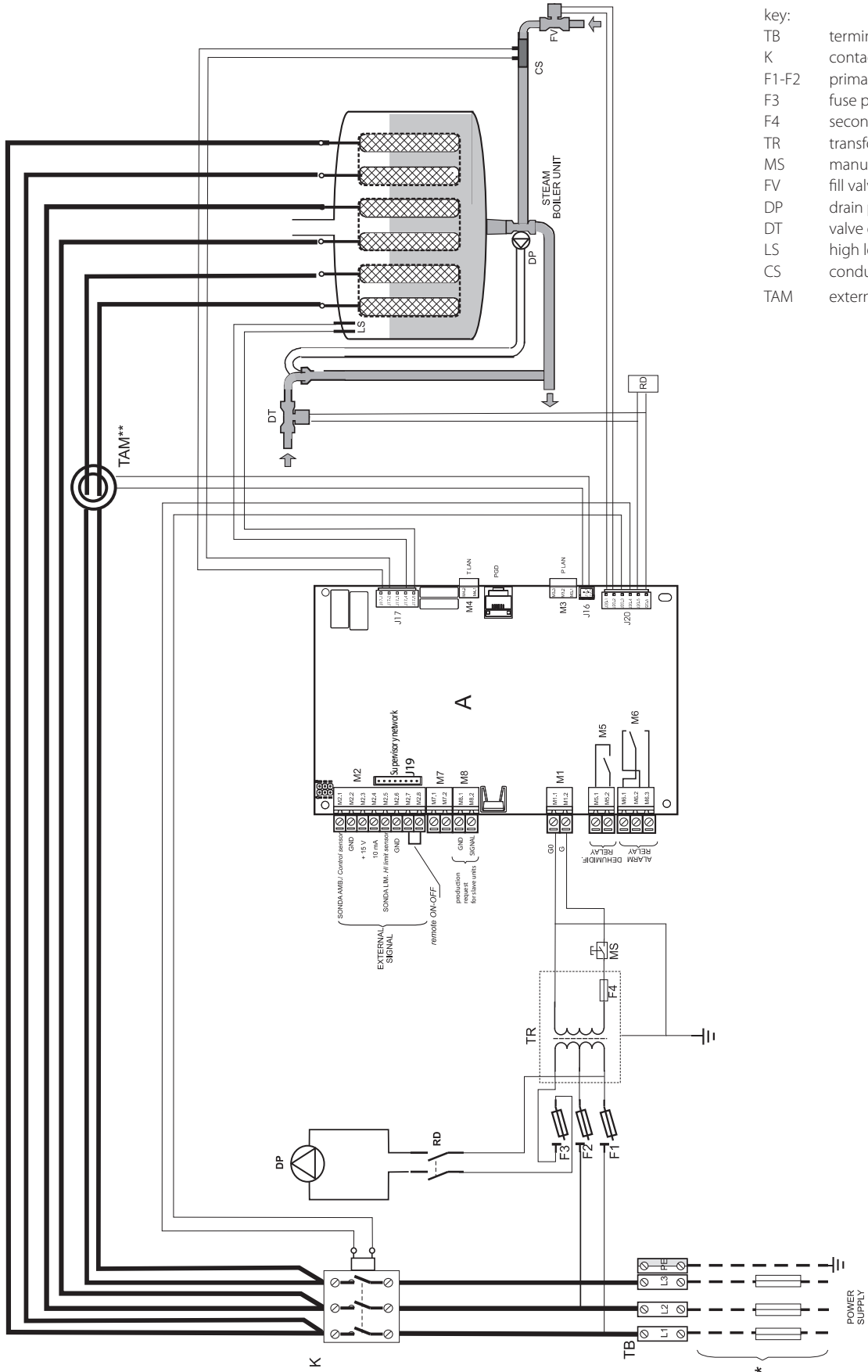

- key:
- TB terminal block
- K contactor
- F1-F2 primary fuses
- F3 fuse protection drain pump
- F4 secondary fuse
- TR transformer
- MS manual switch
- FV fill valve
- DP drain pump
- DT valve drain tempering
- LS high level electrodes
- CS conductivity meter
- TAM external TAM

(\*\*) Attention: for TAM configurations and connections see par. 13.1

12.4 Diagram of three-phase models UE045 (208-230 V) and UE065 (460-575 V)

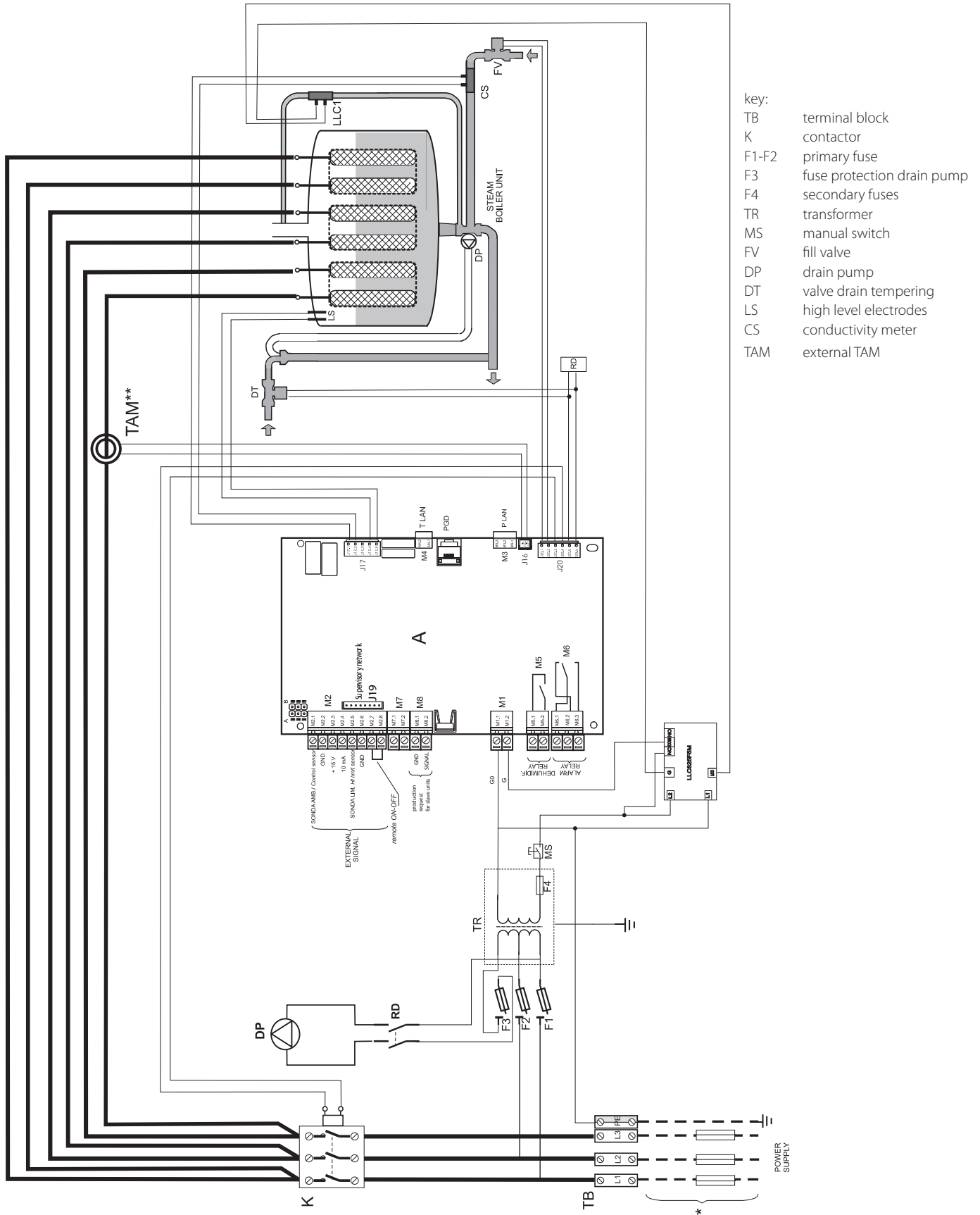

installer

user

service

(\*\*) Attention: for TAM configurations and connections see par. 13.1

12.5 Diagram of three-phase models UE090 to UE130

installer

user

service

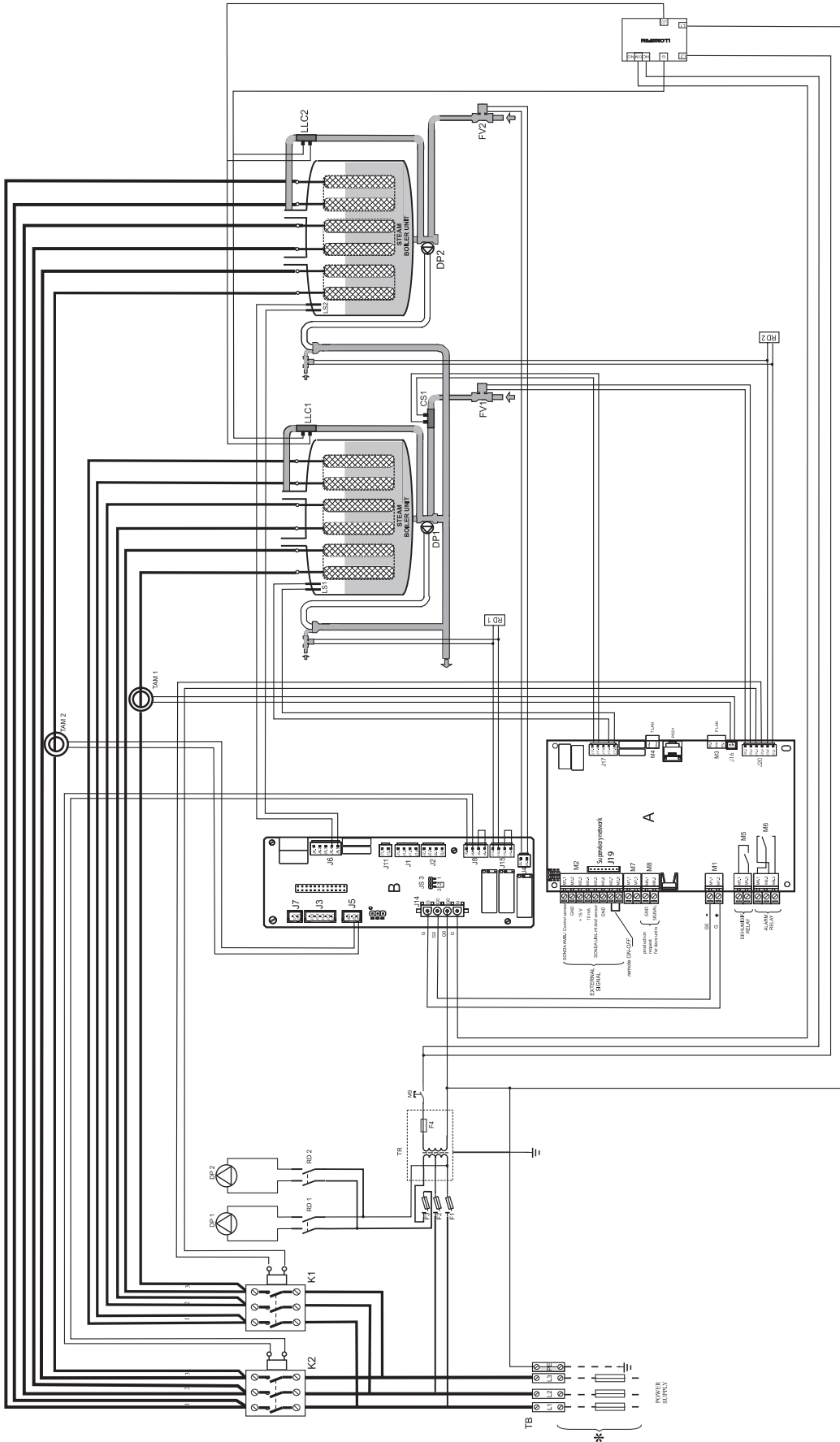

- key:
- TB terminal block
  - K contactor
  - F1-F2 primary fuses
  - F3 secondary fuse
  - F4 fuse protection drain pump
  - TR transformer
  - MS manual switch
  - FV 1-2 fill valve
  - DP 1-2 drain pump
  - LS 1-2 high level electrodes
  - CS 1-2 conductivity meter
  - TAM 1-2 external TAM
  - DT 1-2 valve drain tempering
  - LLC1-2 liquid level control

(\*\*) Attention: for TAM configurations and connections see par. 13.1

## 13. GENERAL FEATURES AND MODELS

### 13.1 humiSteam models and electrical specifications

model	steam production <sup>(2,4)</sup> (kg/h) (lbs/hr)	power <sup>(2)</sup> (kW)	power supply			nominal specifications		cable <sup>(3)</sup> (mm <sup>2</sup> ) / (AWG)	recommended External fuses sizes <sup>(3)</sup> (A / type)	wiring diagram (Fig.)
			code	voltages <sup>(1)</sup> (V - type)	current <sup>(2)</sup> (A)	TAM configuration <sup>(5)</sup>				
UE001	1.5 / 3.3	1.1	U	208 - 1~	5.4	13.a	100	1.5 / 16	10 A / fast blow	12.1
			D	230 - 1~	4.9	13.a	100	1.5 / 16	10 A / fast blow	12.1
UE003	3.0 / 6.6	2.2	U	208 - 1~	10.8	13.d	300	2.5/14	16 A / fast blow	12.1
			D	230 - 1~	9.8	13.d	300	2.5/14	16 A / fast blow	12.1
			W	208 - 3~	6.2	13.a	100	1.5 / 16	10 A / fast blow	12.2
			K	230 - 3~	5.6	13.a	100	2.5/14	16 A / fast blow	12.2
			M	460 - 3~	2.8	13.d	100	1.5 / 16	10 A / fast blow	12.2
UE005	5.0 / 11.0	3.7	U	208 - 1~	18.0	13.e	300	6/10	32 A / fast blow	12.1
			D	230 - 1~	16.3	13.e	300	6/10	32 A / fast blow	12.1
			W	208 - 3~	10.4	13.c	300	2.5/14	16 A / fast blow	12.2
			K	230 - 3~	9.4	13.c	300	2.5/14	16 A / fast blow	12.2
			M	460 - 3~	4.7	13.a	100	1.5 / 16	10 A / fast blow	12.2
			N	575 - 3~	3.8	13.a	100	1.5 / 16	10 A / fast blow	12.2
UE008	8.0 / 17.6	6.0	W	208 - 3~	16.7	13.c	300	6/10	32 A / fast blow	12.2
			K	230 - 3~	15.1	13.c	300	6/10	32 A / fast blow	12.2
			M	460 - 3~	7.5	13.a	100	2.5/14	16 A / fast blow	12.2
			N	575 - 3~	6.0	13.a	100	2.5/14	16 A / fast blow	12.2
UE009	9.0 / 19.8	6.7	U	208 - 1~	31.37	13.a	500	16/6	50A / fast blow	12.1
			D	230 - 1~	29.3	13.a	500	10/8	40 A / fast blow	12.1
UE010	10.0 / 22.0	7.5	W	208 - 3~	18.8	13.c	300	6/10	32 A / fast blow	12.2
			K	230 - 3~	10.8	13.c	300	2.5/14	16 A / fast blow	12.2
			M	460 - 3~	9.4	13.a	100	2.5/14	16 A / fast blow	12.2
			N	575 - 3~	7.5	13.d	300	2.5/14	16 A / fast blow	12.2
			W	208 - 3~	31.2	13.c	500	10/8	40 A / fast blow	12.2
UE015	15.0 / 33.0	11.2	K	230 - 3~	28.2	13.c	500	16 / 0	32 A / fast blow	12.2
			M	460 - 3~	14.1	13.a	300	10/8	20 A / fast blow	12.2
			N	575 - 3~	11.3	13.a	300	4 / 10	16 A / fast blow	12.2
			M	460 - 3~	16.9	13.a	500	6 / 10	32 A / fast blow	12.2
UE018	18 / 39.7	13.5	N	575 - 3~	13.57	13.a	500	6 / 10	32 A / fast blow	12.2
			W	208 - 3~	52.0	13.b	500	25 / 3	80 A / fast blow	12.3
UE025	25 / 55.1	18.7	K	230 - 3~	47.1	13.b	500	25 / 3	63 A / fast blow	12.3
			M	460 - 3~	23.5	13.c	500	10/8	32A / fast blow	12.3
			N	575 - 3~	18.8	13.c	500	6/10	25A / fast blow	12.3
			W	208 - 3~	72.9	13.c	700	35 / 4	100 A / fast blow	12.3
UE035	35 / 77.2	26.2	K	230 - 3~	65.9	13.c	700	35 / 4	100 A / fast blow	12.3
			M	460 - 3~	32.9	13.c	500	16 / 6	50 A / fast blow	12.3
			N	575 - 3~	26.4	13.c	500	10/8	40 A / fast blow	12.3
			W	208 - 3~	93.68	13.b	700	70 / 2	125 A / fast blow	12.4
UE045	45 / 99.2	33.7	K	230 - 3~	84.72	13.b	700	70 / 2	125 A / fast blow	12.4
			M	460 - 3~	42.4	13.c	700	16 / 6	60 A / fast blow	12.3
			N	575 - 3~	33.9	13.c	700	16 / 6	50 A / fast blow	12.3
			M	460 - 3~	61.19	13.b	700	35 / 4	100 A / fast blow	12.4
UE065	65 / 143.3	48.7	N	575 - 3~	48.95	13.b	700	35 / 4	80 A / fast blow	12.4
			M	460 - 3~	84.72	13.c	700	50 / 2	100 A / fast blow	12.5
UE090	90 / 198.4	67.5	N	575 - 3~	67.78	13.c	700	35 / 2	80 A / fast blow	12.5
			M	460 - 3~	122.37	13.b	700	95 / 1/0	160 A / fast blow	12.5
UE130	130 / 286.6	97.5	N	575 - 3~	97.90	13.b	700	70 / 1/0	125 A / fast blow	12.5

Tab. 13.a

- (1) tolerance allowed on the rated mains voltage: -15%, +10%;  
 (2) tolerance on the rated values: +5%, -10% (EN 60335-1);  
 (3) recommended values refer to laying PVC or rubber cables in closed conduits, 20 m (65.6 feet) long; use the local standards, or whichever is more restrictive,  
 (4) rated max instant steam production: the average steam production may be affected by external factors, such as: ambient temperature, water quality, steam distribution system;  
 (5) refer to the wiring diagrams to verify  
 the data are not absolute and if these differ from local standards, the latter must prevail.

## TAM configurations and connections (transformer for measuring the current)

**! Important:** the configurations and connections are already made by CAREL, and no changes are required. The following diagrams represent possible connection modes and may be useful in the event of serious electrical malfunctions on the humidifier. All operations must only be performed by qualified personnel, improper use may cause serious damage.

one cable turn

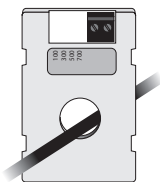

Fig. 13.a

one turn of the two cables of the same phase

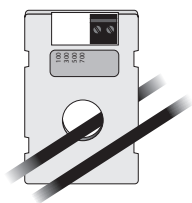

Fig. 13.b

two cable turns of the same phase

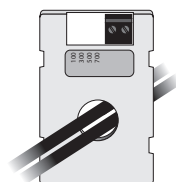

Fig.13.c

one cable in "double turn" mode

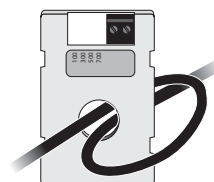

Fig.13.d

three cable turns of the same phase

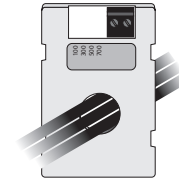

Fig.13.e

**! Important:**

- to avoid interference, separate the power cables from the probe cables.

### 13.2 Technical specifications

technical specifications		UEX models																
		UE001*	UE003*	UE003**	UE005*	UE005**	UE008**	UE009*	UE010**	UE015**	UE018**	UE025**	UE035**	UE045**	UE065**	UE090**	UE130**	
<b>steam</b>																		
connection dia. mm (in)	208-230 V	22/30 (0.9/1.2)			30 (1.2)						1x40 (1x1.6)		2x40 (2x1.6)		--		--	
	460 -575V	22/30 (0.9/1.2)			30 (1.2)						1x40 (1x1.6)		2x40 (2x1.6)		2x40 (2x1.6)		4x40 (2x1.6)	
outlet pressure limits Pa (PSI) (" W.C.)		0/1500 (0/0.218) (6.0)			0/1300 (0/0.188) (5.2)			0/1350 (0/0.196) (5.4)			0/2000 (0/0.290) (8.0)							
<b>supply water</b>																		
connection		3/4" G																
temperature limits °C (°F)		1 to 40 (33.8 to .104)																
pressure limits MPa (PSI)		0.1 to 0.8 (1 to 8 bar) (14.5 to 116.0)																
hardness limits (°fH)		≤ 40																
instant flow-rate l/min (GPM)		0.6 (0.13)			1.1 (0.24)			5.85 (1.3) (7 (1.5) for UE045 to 230Vac)		7 (1.5)		14 (3.0)						
conductivity range (µS/cm)		75 to 1250																
<b>drain water</b>																		
connection dia. mm (in)		40 (1.6)						50 (1.9)										
typical temperature °C (°F)		≤100 (212)																
Drain tempering temperature °C (°F)		≤ 60/ (140)																
instant flow-rate (l/min) (GPM)		7 (1.5)			22.5 (4.9)			45 (9.9)										
instant flow-rate of the drain tempering valve		12 (3.2)			30 (7.9)			30 (7.9)										
<b>environmental conditions</b>																		
ambient operating temp. °C (°F)		1 to .40 (33.8 to .104)																
ambient operating humidity (% rH)		10 to 60																
storage temperature °C (°F)		-10 to 70 (14 to .158)																
storage humidity (% rH)		5 to 95																
index of protection		IP20																
<b>electronic controller</b>																		
controller		HCT																
auxiliary voltage/frequency (V - Hz)		24 / 50/60																
maximum auxiliary power (VA)		90																
probe inputs (general features)		can be selected for the following signals: 0 to 1 Vdc, 0 to 10 Vdc, 2 to 10 Vdc, 0 to 20 mA, 4 to 20 mA, NTC, 135-1000 ohm, 0-135 ohm. input impedance: 60 kΩ with: 0 to 1 Vdc, 0 to 10 Vdc, 2 to 10 Vdc signals 50 Ω with: 0 to 20 mA, 4 to 20 mA signals																
active probe power supply (general features)		15 Vdc. 100 mA protected against short-circuits +1 Vdc with 135 Ω load																
alarm relay outputs(general features)		250 V 5 A (2 A) - type of action-microswitching 1C																
remote enable input (general features)		voltage-free contact; max. resistance 50 Ω; Vmax= 24 Vdc; Imax= 6 mA																
<b>output</b>																		
instant steam production <sup>(1)</sup> kg/h (lb/h)		1.5 (3.3)	3.0 (6.6)	3.0 (6.6)	5.0 (11)	5.0 (11)	8.0 (17.6)	9.0 (19.8)	10.0 (22)	15.0 (33)	18.0 (39.7)	25 (55.1)	35 (77.2)	45 (99.2)	65 (143.3)	90 (198.4)	130 (286.6)	
power input at rated voltage (kW)		1.12	2.25	2.5	3.75	3.75	6.0	6.75	7.5	11.25	13.5	18.75	26.25	33.75	48.75	67.5	97.5	

Tab. 13.b

\* single-phase, \*\* three-phase.

<sup>(1)</sup>= the average steam production is affected by factors such as: ambient temperature, water quality, steam distribution system

### 13.3 Models of steam hoses

code		UEX models															
		UE001X	UE003X	UE005X	UE008X	UE009X	UE010X	UE015X	UE018X	UE025X	UE035X	UE045X	UE065X	UE090X	UE130X		
steam outlet dia. mm (in)		22 (0.9")	22 (0.9")	30 (1.2")	30 (1.2")	30 (1.2")	30 (1.2")	30 (1.2")	30 (1.2")	30 (1.2")	30 (1.2")	40 (1.6")	40 (1.6")	40 (1.6")	2x40 (2x1.6")	2x40 (2x1.6")	4x40 (2x1.6")
max. capacity kg/h (lb/h)		1/1.5 (2.2/3.3)	3 (6.6)	5 (11)	8 (17.6)	9 (19.8)	10 (22)	15 (33)	18 (39.7)	25 (55.1)	35 (77.2)	45 (99.2)	65 (143.3)	90 (198.4)	130 (286.6)		
<b>CAREL steam hoses</b>																	
code		ID mm (in)															
SHOSE00022		22 (0.9")															
SHOSE00030		30 (1.2")															
SHOSE00040		40 (1.6")															

Tab. 13.c

13.4 Models of concentrated jet steam distributors

installer

user

service

UEX models

code	UE001X	UE003X	UE005X	UE008X	UE009X	UE010X	UE015X	UE018X	UE025X	UE035X	UE045X	UE065X	UE090X	UE130X
steam outlet dia. mm (in)	22 (0.9")	22 (0.9")	30 (1.2")	30 (1.2")	30 (1.2")	30 (1.2")	30 (1.2")	30 (1.2")	40 (1.6")	40 (1.6")	40 (1.6")	2x40 (2x1.6")	2x40 (2x1.6")	4x40 (2x1.6")
max. capacity kg/h (lb/h)	1/1.5 (2.2/3.3)	3 (6.6)	5 (11)	8 (17.6)	9 (19.8)	10 (22)	15 (33)	18 (39.7)	25 (55.1)	35 (77.2)	45 (99.2)	65 (143.3)	90 (198.4)	130 (286.6)

CAREL distributors

code	steam inlet dia. mm (in)	max. capacity kg/h (lb/h)													
SDPOEM0012	22 (0.9")	3 (6.6)	1	1	-	-	-	-	-	-	-	-	-	-	-
SDPOEM0022	30 (1.2")	18 (39.7)	1	1	1	1	1	1	1	-	-	-	-	-	-
SDPOEM0000	30 (1.6")	18 (39.7) (with 30mm/1.6" hole)	1	1	1	1	1	1	1	(2)*	(2)*	(4)**	(4)**	-	-

Tab. 13.d

- 1 = the humidifier is connected to just one distributor
- (2) = the humidifier is connected to two distributors (using the "Y" kit: UEKY000000)
- 2 = the humidifier is fitted with two outlets and can be connected to two distributors
- (4) = the humidifier is fitted with two outlets and can be connected to up to four distributors (using two "Y" kits)
- \* = use CAREL "Y" kit code UEKY000000 (40 mm/1.6" inlet and 2 x 30 mm/1.2" outlets)
- \*\* = use CAREL "Y" kit code UEKY000000 (40 mm/1.6" inlet and 2 x 30 mm/1.2" outlets)

13.5 Models of linear distributors

UEX models

code	UE001X	UE003X	UE005X	UE008X	UE009X	UE010X	UE015X	UE018X	UE025X	UE035X	UE045X	UE065X	UE090X	UE130X
steam outlet dia. mm (in)	22 (0.9")	22 (0.9")	30 (1.2")	30 (1.2")	30 (1.2")	30 (1.2")	30 (1.2")	30 (1.2")	40 (1.6")	40 (1.6")	40 (1.6")	2x40 (2x1.6")	2x40 (2x1.6")	4x40 (2x1.6")
max. capacity kg/h (lb/h)	1/1.5 (2.2/3.3)	3 (6.6)	5 (11)	8 (17.6)	9 (19.8)	10 (22)	15 (33)	18 (39.7)	25 (55.1)	35 (77.2)	45 (99.2)	65 (143.3)	90 (198.4)	130 (286.6)

CAREL DP linear distributors

code	steam inlet dia. mm (in)	max. capacity kg/h (lb/h)	length mm (in)												
DP030D22RU	22 (0.9")	4 (8.8)	332 (13.1)	1	1	-	-	-	-	-	-	-	-	-	-
DP045D22RO	22 (0.9")	6 (13.2)	438 (17.2)	1	1	-	-	-	-	-	-	-	-	-	-
DP060D22RO	22 (0.9")	9 (19.8)	597 (23.5)	1	1	-	-	-	-	-	-	-	-	-	-
DP085D22RO	22 (0.9")	9 (19.8)	835 (32.9)	1	1	-	-	-	-	-	-	-	-	-	-
DP030D30RU	30 (1.2")	15 (33)	343 (13.5)	-	-	1	1	1	1	-	-	-	-	-	-
DP045D30RU	30 (1.2")	15 (33)	427 (16.8)	-	-	1	1	1	1	-	-	-	-	-	-
DP060D30RU	30 (1.2")	15 (33)	596 (23.5)	-	-	1	1	1	1	-	-	-	-	-	-
DP085D30RO	30 (1.2")	18 (39.7)	850 (33.5)	-	-	1	1	1	1	(2)*	-	-	-	-	-
DP105D30RO	30 (1.2")	18 (39.7)	1048 (41.3)	-	-	1	1	1	1	(2)*	-	-	-	-	-
DP125D30RO	30 (1.2")	18 (39.7)	1245 (49)	-	-	1	1	1	1	(2)*	-	-	-	-	-
DP165D30RO	30 (1.2")	18 (39.7)	1636 (64.4)	-	-	1	1	1	1	(2)*	-	-	-	-	-
DP060D40RU	40 (1.6")	45 (99.2)	596 (23.5)	-	-	-	-	-	-	1	1	1	2	2	4
DP085D40RO	40 (1.6")	25 (55.1)	834 (32.8)	-	-	-	-	-	-	1	(2)**	(2)**	(4)**	-	-
DP105D40RO	40 (1.6")	35 (77.2)	1015 (40)	-	-	-	-	-	-	1	1	(2)**	2	(4)**	4
DP125D40RO	40 (1.6")	45 (99.2)	1022 (40.2)	-	-	-	-	-	-	1	1	1	2	2	4
DP165D40RO	40 (1.6")	45 (99.2)	1636 (64.4)	-	-	-	-	-	-	1	1	2	2	2	4
DP205D40RO	40 (1.6")	45 (99.2)	2025 (79.7)	-	-	-	-	-	-	1	2	2	2	2	-

Tab. 13.e

- 1 = the humidifier is connected to just one distributor
- (2) = the humidifier is connected to two distributors (using the "Y" kit: UEKY000000)
- 2 = the humidifier is fitted with two outlets and can be connected to two linear distributors
- (4) = the humidifier is fitted with two outlets and can be connected to up to four linear distributors (using two "Y" kits)
- \* = use CAREL "Y" kit code UEKY000000 (40 mm/1.6" inlet and 2 x 30 mm/1.2" outlets)
- \*\* = use CAREL "Y" kit code UEKY40400 (40 mm/1.6" inlet and 2 x 30 mm/1.2" outlets)

For typical installations of the linear distributors, see Figure on page 49

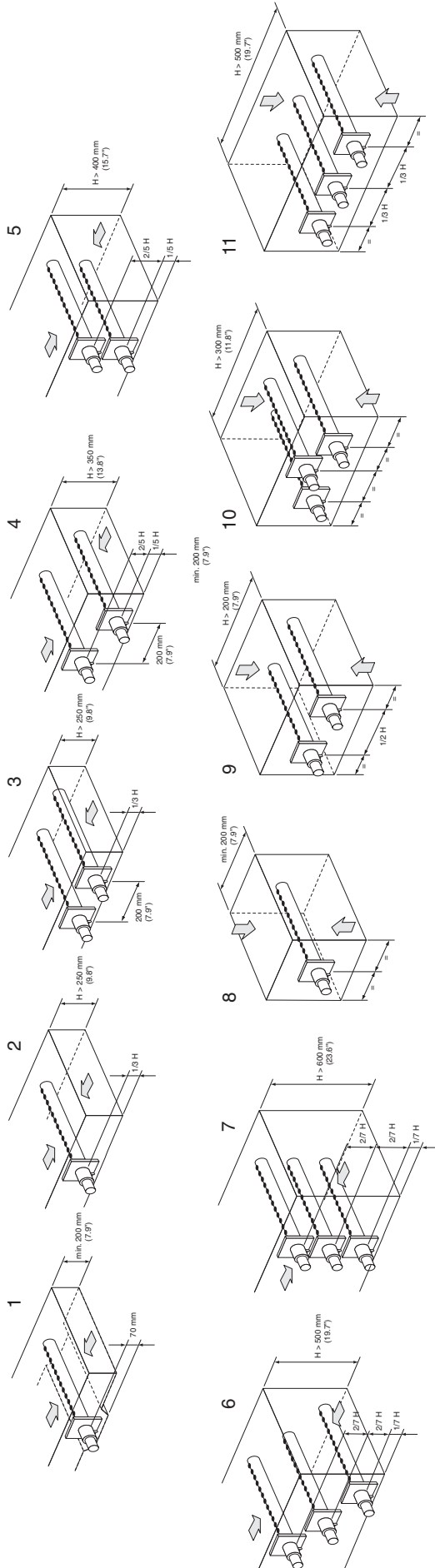

**13.6 CONTROLLING THE BOARD VIA NETWORK**

The variables shown in the list are only some of the total variables available.

DO NOT CONFIGURE VARIABLES THAT ARE NOT SHOWN IN THE TABLE, OTHERWISE THE OPERATION OF THE HUMIDIFIER MAY BE AFFECTED.

<b>"A"</b> CAREL - Modbus®	<b>read (R)/ write (W)</b>	<b>analogue variables* (Modbus®: REGISTERS)</b>
1	R	room probe/external regulator: demand
2	R/W	room probe/external regulator: minimum (calibration)
3	R/W	room probe/external regulator: maximum (calibration)
4	R/W	room probe/external regulator: offset (calibration)
5	R	current production (kg/h)
6	R	limit probe reading
7	R/W	limit probe: minimum (calibration)
8	R/W	limit probe: maximum (calibration)
9	R/W	limit probe: offset (calibration)
10	R	nominal production (kg/h)
11	R	total actual current (a)
12	R	cylinder 1: actual current (a)
13	R	cylinder 2: actual current (a)
14	R/W	maximum production (p0)
15	R/W	%rh set point
16	R/W	%rh differential
17	R/W	limit probe set point
18	R/W	limit differential
19	R/W	temperature set point
20	R/W	temperature differential
21	R/W	dehumidification offset
22	R/W	dehumidification differential
23	R/W	room probe: low humidity warning threshold
24	R/W	room probe: high humidity warning threshold
25	R/W	limit probe: high humidity warning threshold

<b>"D"</b> CAREL - Modbus®	<b>read (R)/ write (W)</b>	<b>digital variables (Modbus®: COILS)</b>
1	R/W	system timer – hour: 1 = variable i24 (hour) can be modified; 0 = i24 cannot be modified
2	R/W	system timer – minute: 1 = variable i25 (minute) can be modified; 0 = i25 cannot be modified
3	R/W	system timer – day: 1 = variable i26 (day) can be modified; 0 = i26 cannot be modified
4	R/W	system timer – month: 1 = variable i27 (month) can be modified; 0 = i27 cannot be modified
5	R/W	system timer - year: 1 = variable i28 (year) can be modified; 0 = i28 cannot be modified
6	R/W	system timer - weekday: 1 = variable i29 (weekday) can be modified; 0 = i29 cannot be modified
7	R/W	measure system: 0 = international system 1 = british system
8	R/W	remote on/off from network: 0 = ue disabled, 1 = ue enabled
9	R	at least 1 alarm is active

10	R	humidistat status: 0 = open, 1 = closed
11	R	remote on/off status: 0 = open = ue disabled 1 = closed = ue enabled
12	R	high conductivity alarm
13	R	high conductivity warning
14	R	cylinder 1: high current alarm
15	R	cylinder 1: low current alarm
16	R	cylinder 1: lack of water alarm
17	R	cylinder 1: low production alarm
18	R	cylinder 1: drain alarm
19	R	cylinder 1: full without demand alarm
20	R	cylinder 1: maintenance-due alarm (timed)
21	R	cylinder 1: pre-exhaustion warning
22	R	cylinder 1: foam warning
23	R	cylinder 1: totally exhausted warning
24	R	cylinder 1: maintenance-due warning (timed)
25	R	cylinder 2: high current alarm
26	R	cylinder 2: low current alarm
27	R	cylinder 2: lack of water alarm
28	R	cylinder 2: low production alarm
29	R	cylinder 2: drain alarm
30	R	cylinder 2: full without demand alarm
31	R	cylinder 2: maintenance-due alarm
32	R	cylinder 2: pre-exhaustion warning
33	R	cylinder 2: foam warning
34	R	cylinder 2: totally exhausted warning
35	R	cylinder 2: maintenance-due warning
36	R	warning: room probe/external regulator not properly connected (only when their signal is 2-10 v or 4-20 ma)
37	R	warning: limit probe not properly connected (only when their signal is 2-10 v or 4-20 ma)
38	R	room high humidity warning
39	R	room low humidity warning
40	R	limit probe high humidity warning
41	R	hour counter alarm
42	R/W	drain for strong demand reduction: 1 = enabled, 0 = disabled
43	R/W	long-inactivity drain: 1 = enabled, 0 = disabled
44	R/W	total periodical flush: 1 = enabled, 0 = disabled
45	R/W	dehumidification: 1 = enabled, 0 = disabled
46	R/W	dilution drain with contactor opened: 1 = enabled, 0 = disabled
47	R/W	warnings for pre-exhaustion and complete exhaustion: 1 = enabled, 0 = disabled
48	R/W	cylinders in parallel or series: 0 = parallel, 1 = series
49	R/W	cylinder 1: reset of the hour counter
50	R/W	cylinder 2: reset of the hour counter
51	R/W	alarms reset
52	R/W	cylinder 1: manual drain: 1 = on, 0 = off
53	R/W	cylinder 2: manual drain: 1 = on, 0 = off
54	R/W	cylinder 1: cleaning cycle: 1 = on, 0 = off
55	R/W	cylinder 2: cleaning cycle: 1 = on, 0 = off

"I"		read (R)/ write (W)	integer variables (Modbus®: REGISTERS)
CAREL	Modbus®		
1	129	R	high part sw version
2	130	R	low part sw version
3	131	R	day sw version
4	132	R	month sw version
5	133	R	year sw version
6	134	R	sw release type
7	135	R	sw release number
8	136	R	humidifier status 0 = on duty; 1 = alarm(s) present; 2 = disabled via network; 3 = disabled by timer; 4 = disabled by remote on/off; 5 = disabled by keyboard; 6 = manual control; 7 = no demand
9	137	R	conductivity reading
10	138	R/W	manual force conductivity value
11	139	R	cylinder 1: working phase 0 = not active; 1 = softstart; 2 = start; 3 = production at steady state; 4 = reduced production 5 = production delayed stop; 6 = full flush
12	140	R	cylinder 1: status 0 = no production; 1 = start of evaporation cycle; 2 = water fill; 3 = steam production in progress; 4 = water drain (decision to open the contactor; drain pump still stopped); 5 = water drain (drain pump running); 6 = water drain (drain pump stopped; contactor closing, if open); 7 = humidifier blocked 8 = long-term-inactivity full drain; 9 = flushing of the hydraulic circuit; 10 = full drain by manual or network request; 11 = automatic management of lack of supply water; 12 = total periodic drain
13	141	R	cylinder 2: working phase 0 = not active; 1 = softstart; 2 = start; 3 = production at steady state; 4 = reduced production; 5 = production delayed stop; 6 = full flush
14	142	R	cilindro 2: status 0 = no production; 1 = start of evaporation cycle; 2 = water fill; 3 = steam production in progress; 4 = water drain (decision to open the contactor; drain pump still stopped); 5 = water drain (drain pump running); 6 = water drain (drain pump stopped; contactor closing, if open); 7 = humidifier blocked 8 = long-term-inactivity full drain; 9 = flushing of the hydraulic circuit; 10 = full drain by manual or network request; 11 = automatic management of lack of supply water; 12 = total periodic drain
15	143	R/W	regulation type: 0 = on/off; 1 = slave 0-100%; 2 = slave 0-100% + limit probe; 3 = %rh control with external probe without limit probe 4 = %rh control with external probe + limit probe; 5 = temperature control
16	144	R/W	room probe/ext. regulator: type of signal 0 = 0-1 v; 1 = 0-10 v; 2 = 2-10 v; 3 = 0-20 ma; 4 = 4-20 ma; 5 = ntc carel standard
17	145	R/W	limit probe: type of signal 0 = 0-1 V; 1 = 0-10 V; 2 = 2-10 V; 3 = 0-20 mA; 4 = 4-20 mA; 5 = NTC CAREL standard
18	146	R/W	maintenance time-out
19	147	R/W	periodical flush: period
20	148	R/W	inactivity drain: time-out
21	149	R/W	conductivity warning: threshold
22	150	R/W	conductivity alarm: threshold
23	151	R/W	tuning of dilution frequency: parameter b8
24	152	R/W	tuning of dilution duration: parameter b9
25	153	R	system timer: hour
26	154	R	system timer: minute
27	155	R	system timer: day
28	156	R	system timer: month
29	157	R	system timer: year
30	158	R	system timer: week day
31	159	R/W	system timer: week day (can be edited for updating the sistem timer!) 0 = monday; 1 = tuesday; 2 = wednesday; 3 = thursday; 4 = friday; 5 = saturday; 6 = sunday
32	160	R/W	system timer: hour (can be edited for updating the sistem timer!)
33	161	R/W	system timer: minute (can be edited for updating the sistem timer!)

34	162	R/W	system timer: day (can be edited for updating the sistem timer!)
35	163	R/W	system timer: month (can be edited for updating the sistem timer!)
36	164	R/W	system timer: year (can be edited for updating the sistem timer!)
37	165	R	cylinder 1: hour counter
38	166	R	cylinder 2: hour counter
39	167	R	voltage type (v): 0 = 200; 1 = 208; 2 = 230; 3 = 400; 4 = 460; 5 = 575
40	168	R/W	humidifier type
52	180	R	lista modelli umidificatori

# 14. TECHNICAL APPENDIX

## 14.1 Operating principle

Immersed electrode humidifiers produce steam by boiling the water contained inside the cylinder. The heat required to boil the water is produced by passing an electrical current through the water in the cylinder. This is done by applying a voltage to the electrodes immersed in the water.

Initially, when the cylinder is new or has just been cleaned, the current depends almost exclusively on the type of supply water: the more salts/minerals in the water, the higher the current, and the required steam production is achieved quicker. Over time the salt deposits in the cylinder increase (these do not evaporate with the water), helping achieve the rated production. In steady operation, the level of production required is maintained automatically by controlling the current input, adjusting the level of water in the cylinder.

The salts that deposit over time cause the progressive depletion of the cylinder. To avoid excessive accumulation, the humidifier automatically drains and replenishes a certain quantity of water at set intervals.

## 14.2 Control principles

### ON/OFF Control

The action is all or nothing, activated by an external contact that consequently determines the control set point and differential.

The external contact may be a humidistat, whose status determines the operation of the humidifier:

- contact closed: the humidifier produces steam if the remote ON/OFF contact is also closed;
- contact open: the production of steam ends.

### Proportional control (see Fig. 14.1)

The production of steam is proportional to the value of a signal "Y" from an external device. The type of signal can be selected between the following standards: 0 to 1 Vdc, 0 to 10 Vdc, 2 to 10 Vdc, 0 to 20 mA, 4 to 20 mA, 0 to 135 Ohm, 135 to 1000 Ohm (installer menu > regulation type > signal type).

The entire range is indicated as proportional band.

The maximum production of the humidifier, corresponding to the maximum value of the external signal, can be set from 20% to 100% of the rated value of the humidifier ("SET" screen > Max. Prod).

In humidifiers with two cylinders in "series" operation, the modulation can be set between 10% and 100% (in "parallel" operation it remains between 20% and 100%).

The minimum production has an activation hysteresis,  $h_y$ , equal to 5% of the range of the proportional band BP of the external signal "Y".

**Nota:** Operation in parallel sequence or series sequence are

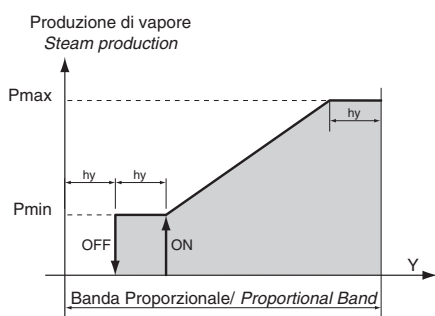

Fig. 14.1 Proportional control

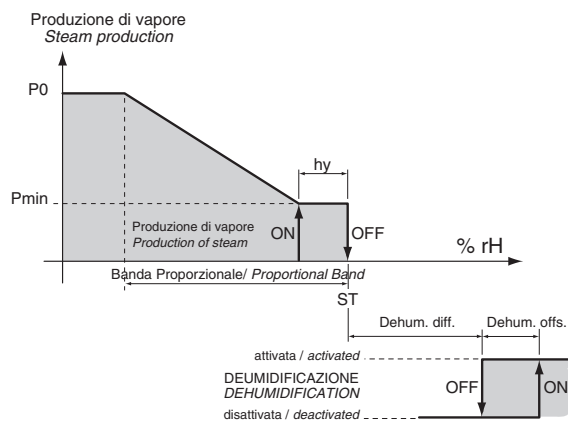

Fig. 14.2 Control with main probe

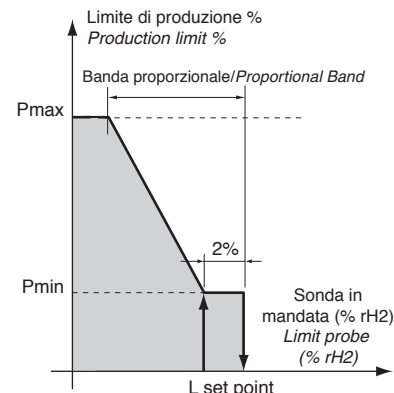

Fig. 14.3 Control with limit probe

available only in models UE090...UE130.

### Proportional control with limit probe (see Figs. 14.1 and 14.3)

See "proportional control", with the addition of a limit probe, generally installed in the air duct downstream of the humidifier.

This type of control is used to reduce steam production if the relative humidity, downstream of the humidifier, is within the proportional band set for the limit probe. Steam production is stopped if the relative humidity, downstream of the humidifier, reaches the limit set point %rH2.

To set the set point and differential for the limit probe: "SET" screen > set point limit and proportional band.

### Independent control with relative humidity probe (see Fig. 14.2)

The production of steam is related to the reading of the probe and increases as the relative humidity value read decreases. The production reaches the maximum when the relative humidity is lower than the set point ( $S_t$ ) by a value at least equal to the proportional band. The maximum production may be programmed between 20% and 100% of the rated value of the humidifier (and between the 10% and 100% in series operation). To set the set point and differential for the main control probe: "SET" screen > set point and proportional band. The minimum production has an activation hysteresis,  $h_y$ , equal to 2% of the range.

The dehumidification function (if enabled) activates a relay output that can be connected to a dehumidifier, for complete humidity control in the environment. The dehumidification relay is activated when the relative humidity measured by the probe, exceeds the set point ( $S_t$ ) by a certain value (Dehum. diff.) plus an offset (Dehum. offset), and is deactivated when the humidity falls below a value equal to the offset.

To check that the relative humidity measured by the probe is within certain preset values, two alarm thresholds can be set in independent control:

- high humidity alarm threshold;
- low humidity alarm threshold.

When these thresholds are exceeded, an alarm is activated, after a set delay.

### Independent control with relative humidity probe and outlet humidity limit (Figs. 14.2 and 14.3)

See control with main probe, combined with a limit probe, installed in the air duct downstream of the humidifier.

This type of control is used to reduce steam production if the relative humidity, downstream of the humidifier, is within the proportional band of the limit probe. Steam production is stopped if the relative humidity, downstream of the humidifier, reaches the limit set point %rH2.

If this mode is activated, if the probe limit is disconnected, (alarm E4) steam production will continue according to read only the main probe.

### Independent control with temperature probe

See the paragraph on "Independent control with relative humidity probe". The unit of measure in this case is °C (°F).

## 14.3 Operation with two cylinders (only UE090...UE130)

The humidifier uses two cylinders to produce steam. The operation of each cylinder, as well as the management of the corresponding alarms, is independent. If one cylinder stops steam production (e.g. alarm in progress), the other continues operation.

There are two types of operation with two cylinders: "parallel sequence" and "series sequence" (installer menu > regulation type > cylinder sequence).

### Parallel sequence (default mode)

In this sequence the two cylinders work so as to produce, in percentage terms, the same quantity of steam. The steam request is divided into two equal parts, so that each cylinder produces exactly half the overall requirement. As the minimum production of each cylinder is 20%, the minimum production of the humidifier is 20% of the total rated value.

In parallel sequence the wear on the cylinders during the life of the humidifier is very similar (they are used in the same mode and for the same time).

### Series sequence

In this mode the first cylinder works more than the first, in both percentage and time terms. The total steam request is divided between the two cylinders in the following way:

- if the request is less than 50% in steady operation, only the first cylinder will be operating,
- if the request exceeds 50% the second cylinder will also be activated.

The minimum production may be as low as 10%.

In series operation the first cylinder becomes depleted more quickly than the second.

### Compensation logic

To ensure the delivery of the required quantity of steam, the controller manages the operation of the two cylinders so that, if one of the two cannot deliver the amount required, the other is automatically activated to make up the difference.

This logic is very important, especially in cases where one of the two cylinders is stopped by an alarm.

## 14.4 Supply water conductivity

Conductivity measurement and alarms

The conductivity of the supply water is measured by the conductivity meter when the fill solenoid valve is opened.

Two alarm thresholds are available (installer menu > water conductivity > warning/alarm):

- warning threshold (default 1000 uS/cm), signal only without activating the alarm relay (automatic reset when the condition is no longer present);
- alarm threshold (default 1250 uS/cm), unit shutdown with activation of the alarm relay.

The alarm is activated when the reading exceeds one of the two thresholds continuously for 60 minutes, or instantly if the value read is 3 times higher than the threshold.

To disable the alarm signal, simply set the thresholds above the maximum value of the reading.

## Overriding the conductivity of the supply water

In conditions where the supply water has relatively low conductivity, a higher conductivity value can be set (installer menu > water conductivity > override conductivity). In this mode, if during the start-up phase the water touches the high level sensors (with consequent partial draining), and the steam production has not yet reached the rated value, the successive water fill cycles will last longer than the rated value so as to reach steady operation faster.

## 14.5 Automatic draining

The humidifier automatically drains and replaces some of the water contained in the cylinder, to prevent an excessive concentration of salts following the evaporation process.

The drain pump is opened for a set time whenever the conductivity exceeds the maximum limit; this situation is measured indirectly by evaluating the evaporation speed).

During the automatic draining phase, the electrodes are off, so as to prevent the drain water from carrying current.

### Powered draining

To enable powered draining: installer menu > drain options > contactor OFF during drain.

### Duration and frequency of the drain to dilute cycles

The duration and the frequency of the drain to dilute cycles can be set according to the characteristics of the supply water (installer menu > drain options > dilution drain time and frequency). For example, with highly conductive water, the duration and frequency of the drain to dilute cycles should be increased. This will avoid excessive concentrations of salts inside the cylinder.

### Drain due to excess foam

With certain types of supply water, foam may form during the production of steam just above the water. This situation must be resolved, as it may cause water to be released together with the steam. For this purpose, two electrodes are fitted on the top of the cylinder. When these electrodes detect the presence of foam, the humidifier activates a series of repeated drain cycles. If the situation persists, the complete washing of the cylinder is activated.

The complete washing of the cylinder can be disabled, so as to guarantee steam production, even if reduced, in applications where continuity of service is required (installer menu > drain options > disable complete emptying for foam).

### Drain due to inactivity

If the humidifier does not operate for an extended time (it remains on but does not produce steam), the water in the cylinder is drained automatically, to avoid stagnation and hygiene risks.

To disable the periodical drain due to inactivity: installer menu > drain options > drain after inactivity.

To set the inactivity time: installer menu > drain options > inactivity days (default 3 days).

## Draining due to a significant reduction in the request for production

In the event of a significant reduction in the request for steam production, the humidifier, rather than wait for the level of water (and thus the production) to decrease due to the effect of the production itself, performs a drain cycle. The reduction in the request for steam production is considered significant if the current is 33% higher than that relating to the requested level. This function can be disabled: installer menu > drain options > drain if steam request drops.

### Periodical drain

When using water rich in substances such as humus, lime and impurities, the efficiency and the operation of the humidifier may be affected. In these cases, a periodical drain cycle should be set for the cylinder top avoid accumulating residues.

To enable the periodical drain: installer menu > drain options > periodic cylinder flush

To set the drain interval: installer menu > drain options > time interval

## 14.6 Automatic insufficient supply water management

The humidifier checks whether there is no supply water or the flow-rate of supply water is too low, by measuring if the current at the electrodes increases after opening the fill solenoid valve.

In this case, the humidifier:

- activates the alarm relay,
- opens the contactor and closes the fill solenoid valve for 10 minutes

After the 10 minutes, the fill solenoid valve is opened, the contactor closed and the phase current measured: if it increases the alarm is deactivated, otherwise the procedure is repeated.

NOTE: the alarm is reset automatically and is managed according to the procedure described above.

## 14.7 Cylinder “exhaustion” and cylinder “pre-exhaustion” alarms

To disable the “cylinder exhaustion” alarm: installer menu > options > cylinder pre-exhaustion alarm

To set “cylinder exhaustion warning” (maximum operating hours): installer menu > options > cylinder lifetime warning (setting “0” disables the alarm).







## Headquarters

### CAREL INDUSTRIES S.r.l.

Via dell'Industria, 11 - 35020 Brugine - Padova (Italy)  
Tel. (+39) 0499 716611 - Fax (+39) 0499 716600  
carel@carel.com - www.carel.com

### Subsidiaries:

#### CAREL Asia Ltd

Rm. 11, 8/F, Shatin Galleria,  
18 Shan Mei St., Fotan, Shatin - Hong Kong  
Tel. (+852) 2693 6223 - Fax: (+852) 2693 6199  
e-mail: sales@carel-asia.com - www.carelhk.com

#### CAREL Australia Pty Ltd

PO Box 6809, Silverwater B.C. N.S.W. 1811  
Unit 37, 11-21 Underwood Rd Homebush N.S.W. 2140  
Tel: (+612) 8762 9200 - Fax: (+612) 9764 6933  
e-mail: sales@carel.com.au - www.carel.com.au

#### CAREL China - CAREL Electronic (Suzhou) Co. Ltd.

No. 26, 369 Lushan Road,  
Suzhou City, Jiangsu Province,  
215129 P.R. of China  
Tel: (+865) 12 66628098 - Fax: (+865) 12 66626631  
e-mail: sales@carel-china.com - www.carel-china.com

#### CAREL Deutschland GmbH

Am Spielacker, 34, 63571 Gelnhausen (Germany)  
Tel. (+49) 6051 96290 - Fax (+49) 6051 962924  
e-mail: info@carel.de - www.carel.de

#### CAREL France Sas

32, rue du Champ Dolin - 69800 Saint Priest, France  
Tel. (+33) 472 47 88 88 - Fax (+33) 478 90 08 08  
e-mail: carelfrance@carelfrance.fr - www.carelfrance.fr

#### CAREL Ibérica

C/ Laureà Miró, 410 Nau 10  
08980 Sant Feliu de Llobregat - Barcelona  
Tel. (+34) 933 298 700 - Fax. (+34) 933 298 700

#### DELEGACIÓN MADRID

Nunez de Balboa, 116, 5a pl., Oficina 530  
28006 MADRID  
tel. (+34) 916 375 966 - Fax: (+34) 916 373 207  
e-mail: info@carel.es - www.carel.es

#### CAREL Sud Africa

Unit B5, Lanzerac Estate, Old Pretoria Road, Midrand  
PO Box 5294 Halfway House 1685, South Africa  
Tel: +27 (0)11 805 1558  
Fax: +27 (0)11 805 1090  
e-mail: info@carelcontrols.co.za - www.carelcontrols.co.za

#### CAREL Sud America Ltda

Avenida Dourado, 587 - Cep. 13.280-000 Vinhedo - São Paulo (Brasil)  
Tel (+55) 19 38 26 25 65 - Fax (+55) 19 38 26 25 54  
e-mail: carelsudamerica@carel.com.br - www.carel.com.br

#### CAREL U.K. Ltd

Unit 6, Windsor Park Industrial Estate, 50 Windsor Avenue  
Merton SW19 2TJ, London (United Kingdom)  
Tel. (+44) 208 545 9580 - Fax (+44) 208 543 8018  
e-mail: careluk@careluk.co.uk - www.careluk.co.uk

#### CAREL U.S.A. L.L.C

385 South Oak Street  
Manheim, PA 17545, Pennsylvania (USA)  
Tel. (+1) 717-664-0500 - Fax (+1) 717-664-0449  
e-mail: sales@carelusa.com - www.carelusa.com

www.carel.com

### Affiliates:

#### CAREL Korea Co. Ltd.

A-901, Chung Ang Circ. Complex  
1258 Kuro Bon-Dong, Kuro-KU,  
Seoul-KOREA  
Tel: (+82) 02 2068 8001  
Fax: (+82) 02 2068 8005  
e-mail: info@carel.co.kr - www.carel.co.kr

#### CAREL Ireland

FarrahVale Controls & Electronics Ltd  
28E Ashbourne Business Centre  
County Meath - IRELAND  
Tel: (+353) 1 8353745  
Fax: (+353) 1 8353681  
www.carel.com - info@carel.ie

#### CAREL Spol (Czech and Slovakia) s.r.o. Prazska 298

250 01 Brandys nad Labem, Czech Republic.  
Tel: (+420) 326 377 729  
Fax: (+420) 326 377 730  
e-mail: carel@carel-cz.cz - www.carel-cz.cz

#### CAREL Thailand Co., Ltd.

444 4th Floor OlympiaThai Building, Ratchadapisek Road,  
Samsennok, Huaykwang, Bangkok 10310 Thailand  
Tel: (+66) 2 513 5610  
Fax: (+66) 2 513 5611  
e-mail: info@carel.co.th - www.carel.co.th

#### CAREL Turkey

CFM Sogutma ve Otomasyon San. Tic. LTD  
1201 Sok. No: 13/Z 21  
Izmir - TURKEY  
Tel: (+90) 232 4590888  
Fax: (+90) 232 4593435  
www.cfmsohutma.com - info@cfmsogutma.com

Agency: